



DEFENDER SERIES® SPILL CONTAINERS

Defender Series® five gallon spill containers combine years of knowledge and experience in forecourts across the globe to represent the next generation in spill containment. The Defender Series® adapts alongside evolving environmental regulations with the latest innovations in spill containment. Get the best defense and quality construction with the Defender Series®.

Highlights

Fugitive Emission Protection

Proactively protecting a site from the dangers of fugitive emissions can save station owners both time and money by avoiding remediation due to fuel leakage. The Defender Series® provides several key defenses from these costly expenses:

- 1 ¼" compression gasket provides a vapor tight mechanical seal.
- Drop tube compression adapter ensures a vapor tight seal.
- Drain valve designed to meet CARB leak rate requirements.
- Concentrated secondary containment catch basin provides immediate notification of integrity breach

Integrity Confirmation

Always know how your spill containment is performing and get immediate confirmation on the integrity of the interstitial space with the following Defender Series® features:

- I² (Interstitial Integrity) monitor facilitates efficient monthly and annual visual inspections confirming the integrity of the secondary containment space.
- Electronic liquid detection sensor option available with proven INCON® brand TSP-ULS (Universal Liquid Sensor) for active leak detection.
- TSP-ULS wiring penetrates side wall of gravel guard ensuring no additional installation height requirement.

Minimized Maintenance Costs

Maximize your business's value and minimize installation and maintenance expenses with features like:

- Field replaceable containment – replace easily without having to break concrete; simply loosen the four plow ring bolts to remove and replace interior containment.
- Plow ring bolts are protected – located inside the interior of the container, shielding them from the potential wear and tear of the forecourt environment.
- Variable height adjustments – allows for an installation height between 14 ½" and 17-5/8", for easy installation in retrofit applications.

Variable Installation Height

The Defender Series® double wall and single wall field replaceable spill container was designed with the retrofit application in mind. The variable height adjustment feature allows an installation height range of 14 ½" to 17-5/8" which minimizes the number of retrofit spill containment options needed to replace existing direct bury containments. This reduces the need to replace tank risers and ultimately reduces the retrofit installation time.

Double Wall Upgradeability

As regulations change, it may become necessary to upgrade a single wall spill container to meet future requirements. The Defender Series® spill container allows the single wall option to be converted into a double wall spill container simply by removing the snowplow ring, removing the single wall containment, threading the secondary contained spill container onto the existing tank riser and then reinstalling the snowplow ring.

Specifications

- Exceeds H20 and HS20 load standards (maximum axle load requiring support for the 32,000 or 16,000 pounds for each set of dual tire wheels).

Approvals

- ULC Listed (CI-GKT versions only).
- CARB approved.

Ordering Information

Ordering Guide

Complete spill container part numbers have a specific order and are created using the following guidelines:

705 XXX YAB CI-GKT

XXX = Containment Options

- 545 = Single wall
- 555 = Double wall

Y = Interstitial Monitoring Options

- 0 = No sensor
- 1 = I² Monitor (float gauge)
- 2 = TSP-ULS Sensor

A = Base Thread Options

- 0 = NPSM
- 1 = NPT
- 2 = BSPT

B = Drain Options

- 1 = With Drain
- 2 = Without Drain

CI-GKT = Lid

CI-GKT is a standard black epoxy-coated cast iron gasketed lid. Call factory for additional lid options.

Example: 70555111CI-GKT = Double wall Defender Series® spill container with I² monitor, with NPT base thread, with drain and with standard cast iron gasketed lid.

Defender Series™ Spill Containers

Model	Description
705545001CI-GKT	Defender Series® 5 gallon spill container, single wall, NPSM thread, with drain, with gray epoxy-coated cast iron gasketed lid
705545002CI-GKT	Defender Series® 5 gallon spill container, single wall, NPSM thread, without drain, with gray epoxy-coated cast iron gasketed lid
70555101CI-GKT	Defender Series® 5 gallon spill container, double wall, NPSM thread, with drain, with I ² monitor, with gray epoxy-coated cast iron gasketed lid
70555102CI-GKT	Defender Series® 5 gallon spill container, double wall, NPSM thread, without drain, with I ² monitor, with gray epoxy-coated cast iron gasketed lid
70555201CI-GKT	Defender Series® 5 gallon spill container, double wall, NPSM thread, with drain, with TSP-ULS sensor, with gray epoxy-coated cast iron gasketed lid
70555202CI-GKT	Defender Series® 5 gallon spill container, double wall, NPSM thread, without drain, with TSP-ULS sensor, with gray epoxy-coated cast iron gasketed lid
705545001**	Defender Series® 5 gallon spill container, single wall, NPSM thread, with drain, no cover
705545002**	Defender Series® 5 gallon spill container, single wall, NPSM thread, without drain, no cover
705545002CI-GKT	Defender Series® 5 gallon spill container, single wall, NPSM thread, without drain, with gray epoxy-coated cast iron gasketed lid
70555101CI-GKT	Defender Series® 5 gallon spill container, double wall, NPSM thread, with drain, with I ² monitor, with gray epoxy-coated cast iron gasketed lid
70555102CI-GKT	Defender Series® 5 gallon spill container, double wall, NPSM thread, without drain, with I ² monitor, with gray epoxy-coated cast iron gasketed lid
70555201CI-GKT	Defender Series® 5 gallon spill container, double wall, NPSM thread, with drain, with TSP-ULS sensor, with gray epoxy-coated cast iron gasketed lid
705545011CI-GKT	Defender Series® 5 gallon spill container, single wall, NPT thread, with drain, with gray epoxy-coated cast iron gasketed lid
705545012CI-GKT	Defender Series® 5 gallon spill container, single wall, NPT thread, without drain, with gray epoxy-coated cast iron gasketed lid
705545021CI-GKT	Defender Series® 5 gallon spill container, single wall, BSPT thread, with drain, with gray epoxy-coated cast iron gasketed lid
705545022CI-GKT	Defender Series® 5 gallon spill container, single wall, BSPT thread, without drain, with gray epoxy-coated cast iron gasketed lid
70555111CI-GKT	Defender Series® 5 gallon spill container, double wall, NPT thread, with drain, with I ² monitor, with gray epoxy-coated cast iron gasketed lid
70555112CI-GKT	Defender Series® 5 gallon spill container, double wall, NPT thread, without drain, with I ² monitor, with gray epoxy-coated cast iron gasketed lid
70555121CI-GKT	Defender Series® 5 gallon spill container, double wall, BSPT thread, with drain, with I ² monitor, with gray epoxy-coated cast iron gasketed lid
70555211CI-GKT	Defender Series® 5 gallon spill container, double wall, NPT thread, with drain, with TSP-ULS sensor, with gray epoxy-coated cast iron gasketed lid
70555212CI-GKT	Defender Series® 5 gallon spill container, double wall, NPT thread, without drain, with TSP-ULS sensor, with gray epoxy-coated cast iron gasketed lid
705559901*	Defender Series® spill container cutaway display, double wall, with drain, with I ² monitor

*For display and demonstration purposes only. Six to eight week lead time.

** Not ULC listed

Defender Series® Spill Container Installation Tools

Model	Description
T-7001	T-handle wrench
T-7106	Double-ended installation tool
T-7107	Double wall vacuum test kit (for double wall models only)

Ordering Information continued

Single Wall Defender Series® Replacement Parts

#	Model	Description
1	70544011	Cover, cast iron w/gasket (black)
2	70551911	Cover gasket
3	70553001	Plow ring assembly
4	602009007	Plow ring gasket
5	70541202	Fill riser, cap, and adapter kit
6	77720102	Top seal fill cap
7	SWF-100-SS	Fill swivel adapter
8	70521307	4" x 2.88" close nipple
9	70541302	Vapor riser, cap, and adapter kit
10	30430103	Top seal vapor cap
11	SWV-101-SS	Vapor swivel adapter
12	70550901EC	DT riser clamp assembly
13	1103939	DT riser gasket
14	70533729	Pull-to-push drain valve kit
15	70550311	Spill container seal ring gasket
16	602256001	Tank riser gasket
17	705545001SP	Spill container, NPSM, with drain
	705545002SP	Spill container, NPSM, no drain
	705545011SP	Spill container, NPT, with drain
	705545012SP	Spill container, NPT, no drain

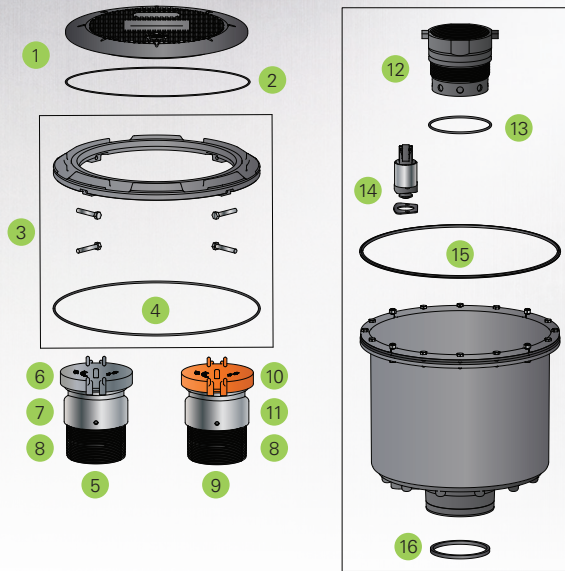

Double Wall Defender Series® Replacement Parts

#	Model	Description
1	70544011	Cover, cast iron w/gasket (black)
2	70551911	Cover gasket
3	70553001	Plow ring assembly
4	602009007	Plow ring gasket
5	70541202	Fill riser cap and adapter kit
6	77720102	Top seal fill cap
7	SWF-100-SS	Fill swivel adapter
8	70521307	4" x 2.88" close nipple
9	70541302	Vapor riser, cap, and adapter kit
10	30430103	Top seal vapor cap
11	SWV-101-SS	Vapor swivel adapter
12	70550901EC	DT riser clamp assembly
13	1103939	DT riser gasket
14	70533729	Pull-to-push drain valve kit
15	70533301	I ² monitor and inspection port kit
16	TSP-UJS	Electronic leak detection sensor
17	70533302	Sensor inspection port
18	70550311	Spill container seal ring gasket
19	602256001	Tank riser gasket
20	705555101SP	Spill container, I2, NPSM, with drain
	705555102SP	Spill container, I2, NPSM, no drain
	705555111SP	Spill container, I2, NPT, with drain
	705555112SP	Spill container, I2, NPT, no drain
	705555201SP	Spill container, sensor, NPSM, with drain
	705555202SP	Spill container, sensor, NPSM, no drain
	705555211SP	Spill container, sensor, NPT, with drain
	705555212SP	Spill container, sensor, NPT, no drain

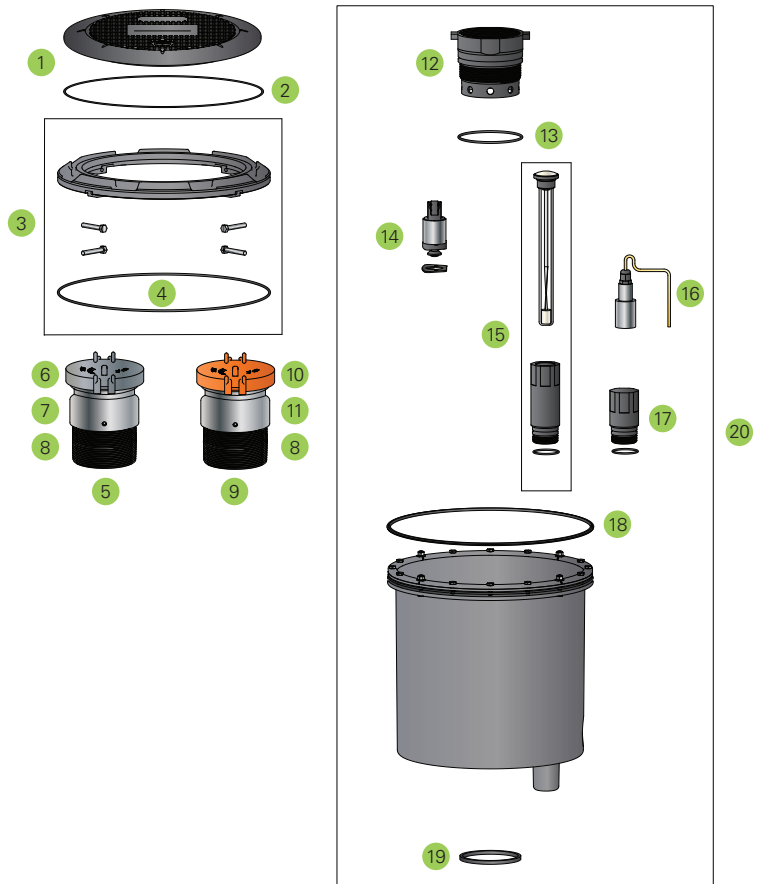

Service Station Hardware