

Electronic Line Leak Detectors

Application Guide



Notice

Veeder-Root makes no warranty of any kind with regard to this publication, including, but not limited to, the implied warranties of merchantability and fitness for a particular purpose.

Veeder-Root shall not be liable for errors contained herein or for incidental or consequential damages in connection with the furnishing, performance, or use of this publication.

Veeder-Root reserves the right to change system options or features, or the information contained in this publication.

This publication contains proprietary information which is protected by copyright. All rights reserved. No part of this publication may be photocopied, reproduced, or translated to another language without the prior written consent of Veeder-Root.

Selecting a Line Leak Detector	1
Line Leak Specifications - Supported Pump Models	1
Line Volume Limits	3
Supported Pipe Types and Line Lengths* - For DPLLD, PLLD and WPLLD	3
Specifications and Compatible Fluids Requirements	5
Check Valve Requirements	6
TLS-450PLUS and TLS-450 Series Consoles - DPLLD	
Hardware Required for DPLLD Leak Detection	7
Digital Pressurized Line Leak Detector (DPLLD) - Order one per line.	7
DPLLD Modules	7
DPLLD Leak Test Options	7
DPLLD Precision Testing Frequencies	7
DPLLD Accessories and Spare Parts	7
TLS-350 Consoles - PLLD	
Hardware Required for PLLD Leak Detection	8
Pressurized Line Leak Detector (PLLD)	8
PLLD Modules	8
PLLD Precision Testing Software Module	8
PLLD Precision Testing Frequencies	8
PLLD Accessories and Spare Parts	9
TLS-350 Consoles - WPLLD	
Hardware Required for Wireless Pressurized Line Leak Detection (WPLLD)	10
WPLLD Modules	10
WPLLD Precision Testing Software Module	10
WPLLD Precision Testing Frequencies	10
WPLLD Accessories & Spare Parts	11
Special Installations	
Manifolded Line Applications	12
Transducer Installation - Red Jacket CPT and Quantum CPT Pumps	12
Transducer Installation - Red Jacket Big-Flo Pumps, Red Jacket Maxxum Pumps and FE Petro High Capacity Pumps	13

Selecting a Line Leak Detector

This guide helps you to properly configure Veeder-Root's line leak equipment for underground pressurized piping. **Note: Following the industry's best practices, a containment sensor is recommended for sites with Pressurized Line Leak Detection (DPLLD, PLLD or WPLLD) in the event that the submersible pump develops a leak before the check valve and/or functional element. Line leak detectors only check leaks in the primary product line downstream from the pump.**

Veeder-Root offers three types of line leak detectors, each uniquely suited to a particular type of application:

- **DPLLD** Digital Pressurized Line Leak Detection
- **PLLD** Pressurized Line Leak Detection
- **WPLLD** Wireless Pressurized Line Leak Detection

DPLLD, PLLD and WPLLD eliminate the need to break the product line for installation or service. In addition, WPLLD installs without running new wires. DPLLD, PLLD and WPLLD are the cost-effective choice for most retrofit and new piping installations. Veeder-Root's electronic line leak detectors have been evaluated by a third party in accordance with EPA evaluation procedures. Please refer to the National Work Group Listings at www.nwglde.org.

FEATURE	DPLLD (8590 Series)	PLLD (8484 Series)	WPLLD (8494 Series)
SUPPORTED CONSOLE			
TLS-450PLUS	YES	NO	NO
TLS-450	YES	NO	NO
TLS-350	NO	YES	YES
LINE LEAK DETECTION			
3 gph Testing	YES	YES	YES
Precision Testing	OPTIONAL	OPTIONAL	OPTIONAL ¹
Positive Shutdown	YES	YES	YES
3rd Party Certified	YES	YES	YES
INSTALLATION REQUIREMENTS			
Requires TLS Console	YES	YES	YES
Installs Without Breaking Piping	YES	YES	YES
Installs Without New Sump	YES	YES	YES
Installs Without New Wires	NO	NO	YES

¹Not available for flexible piping

Line Leak Specifications - Supported Pump Models (Footnotes explained at end of table)

4-INCH FIXED SPEED MODELS		DPLLD/PLLD	WPLLD	
RED JACKET	THE RED JACKET	P75U1RJ1 - RJ3, AGP75S1RJ1 - RJ3 (3/4 HP)	YES	YES
		P150U1RJ1 - RJ3, AGP150S1RJ1 - RJ3 (1-1/2 HP)	YES	YES
		X3P150U1RJ1 - RJ3, X3AGP150S1RJ1 - RJ3 (1-1/2 HP)	YES	YES
		P200U1-3RJ1 - RJ3, AGP200S1RJ1 - RJ3 (2 HP)	YES	YES
	QUANTUM	P33U1 QS1 - QS3, AGP33S1 QS1 - QS3 (1/3 HP)	YES	YES
		P75U1Y QS1 - QS3, AGP75S1Y QS1 - QS3 (3/4 HP)	YES	YES
		P150U1Y QS1 - QS3, AGP150S1Y QS1 - QS3 (1-1/2 HP)	YES	YES
		X3P150U1Y QS1 - QS3, X3AGP150S1Y QS1 - QS3 (1-1/2 HP)	YES	YES
		X5P150U1Y QS1 - QS3, X5AGP150S1Y QS1 - QS3 (1-1/2 HP)	NO	NO
		P200U1-3Y QS1 - QS3, AGP200S1-3Y QS1 - QS3 (2 HP)	YES	YES
	STANDARD	P33R1 T1 - T4 (1/3 HP)	YES	YES
		P75S1 T1 - T4 (3/4 HP)	YES	YES
		P150S1 T1 - T4 (1-1/2 HP)	YES	YES
		X3P150S1 T1 - T4 (1-1/2 HP)	YES	YES
		X5P150S1 T1 - T4 (1-1/2 HP)	NO	NO
	FE PETRO	STP33, STPAG33 (1/3 HP)	YES	YES
STP75, STPAG75 (3/4 HP)		YES	YES	
STP150, STPAG150, STPAGH150 (1-1/2 HP)		YES	YES	
STP200, STPAG200, STPMR200, STPR200 (2 HP)		YES	YES	
STPH200, STPAGH200, STPHMR200, STPHR200 (2 HP)		YES	YES	

TOKHEIM	585-13 (1/3 HP)	YES	NO
	585-34 (3/4 HP)	YES	NO
	585-150 (1-1/2 HP)	YES	NO
BENNETT	ALL	YES	NO

4-INCH VARIABLE SPEED MODELS **DPLLD/PLLD** **WPLLD**

RED JACKET	STD and AG with CPT (2 HP) ^{1,2}	YES	NO
	QUANTUM P200U202Y QS1 - QS3 CPT (2 HP)	YES	NO
	QUANTUM AGP200T202Y QS1 - QS3 CPT (2 HP)	YES	NO
	THE RED JACKET P200U20-2RJ1 - RJ3 (2 HP)	YES	NO
	THE RED JACKET AGP200T20-2RJ1 - RJ3 (2 HP)	YES	NO
	THE RED JACKET VSFC ¹	YES	NO

FE PETRO	IST (2 HP) ¹	YES	NO
	STP VS2, STPAG VS2 (2 HP)	YES	NO
	STPRVS4, ISTVS4 AG	YES	NO
	STPMRVS4, ISTMVS4 AG	YES	NO

6-INCH HIGH CAPACITY MODELS **DPLLD/PLLD** **WPLLD**

RED JACKET - MAXXUM	MAXXUM MXP300 (3 HP)	YES ³	NO
	MAXXUM MXP500 (5 HP)	YES ³	NO
RED JACKET - BIG-FLO	P100H1 - 1MB (1 HP)	YES ⁴	NO
	P150H1 - 1HB (1-1/2 HP)	NO	NO
	P200H1 - 2MB (2 HP)	YES ⁴	NO
	P200H3 - 2MB (2 HP)	YES ⁴	NO
	P300H3 - 2HB (3 HP)	YES ⁴	NO
	P500H3 - 2K (5 HP)	YES ⁴	NO

FE PETRO	STP3, STPAG3 (3 HP)	YES ^{4,6}	NO
	STP5, STPAG5 (5 HP)	YES ^{4,6}	NO
	STP5H (5HP)	YES ^{4,6}	NO

APPLICATIONS **DPLLD/PLLD** **WPLLD**

SIPHON/MANIFOLDED TANKS	YES	YES
MANIFOLDED LINES	YES	YES
ELECTRONIC BLENDERS	YES	YES
MECHANICAL BLENDERS	YES ⁵	NO

¹See Site Preparation and Installation manual for supported settings.

²Requires TLS-350 Version X19 or later software and CPT Transducer Adaptor Kit (Red Jacket P/N 144-326-5).

³USER DEFINED pipe type must be used for precision (0.2 and 0.1 gph) testing.

⁴3.0 gph only testing.

⁵Requires TLS-350 Version 29C or later software (PLLD).

⁶Requires Model 'R' Relief Valve.

Line Volume Limits

Console Type	Transducer Type	Piping Type	3.0 GPH Certified Volume (Gal.)	0.2 GPH Certified Volume (Gal.)	0.1 GPH Certified Volume (Gal.)
SERIES 860091-X01 TLS-450PLUS CONSOLES W/SOFTWARE VERSION 7E OR HIGHER	Series 8590-DPLLD	Rigid	1178.6	1178.6	165.08
		Flexible	1178.6	1178.6	109.84
		Hybrid (Flex & Rigid)	1178.6	1178.6	267.8
SERIES 860090-100 TLS-450 CONSOLES		Rigid	425.84	165.08	165.08
		Flexible	109.84	109.84	109.84
		Hybrid (Flex & Rigid)	535.68	267.8	267.8
SERIES 8482 TLS-350, -350PC, -350R, -350RPC, -350PLUS W/ SOFTWARE VERSION X19 OR HIGHER	Series 8484-PLLD	Rigid	212	119.4	119.4
		Flexible	212	119.4	119.4
		Hybrid (Flex & Rigid)	212	119.4	119.4

Supported Pipe Types and Line Lengths* - For DPLLD, PLLD and WPLLD

*lengths approved are for 3.0, 0.2, & 0.1 gph line leak tests using single pipe types. For mixed line types with DPLLD or PLLD, see footnote 1, 6 & 7 respectively.

PIPE TYPE	TLS-4XX w/ DPLLD ^{6,7} (Length Feet)	TLS-350 w/ PLLD ¹ (Length Feet)	TLS-350 w/ WPLLD ² (Length Feet)	BULK MODULUS ³ (PSI)	VOLUME (Gallons/Foot)
RIGID PIPE					
FIBERGLASS (2 INCH)	10-3660	10-500	10-500	25,000	0.204
FIBERGLASS (3 INCH)	10-2619	10-220	10-220	35,000	0.461
STEEL (2 INCH)	30-3000	30-500	30-500	50,000	0.190
COPPER (1 INCH, TYPE K)	10-500	10-500	No	55,000	0.041
FLEXIBLE PIPE - ADVANCED POLYMER TECHNOLOGY					
1.5-INCH (P150SC)	20-3000	20-1100	No	8800	0.092
1.75-INCH (P175SC)	20-3000	20-850	No	7400	0.125
2.0-INCH (P200SC)	20-3000	20-650	No	5600	0.163
2.5-INCH (P250SC)	20-3000	20-430	No	4400	0.255
1.5-INCH (XP-150-SC)	20-3000	20-1100	No	5042	0.092
2.0-INCH (XP-200-SC)	20-3000	20-650	No	5420	0.163
FLEXIBLE PIPE - AMERON					
DUALOY 3000/FLS III (1.5 INCH)	20-3000	20-1100	No	5400	0.092
DUALOY 3000/FLS III (2.0 INCH)	20-3000	20-650	No	7600	0.163
FLEXIBLE PIPE - BRUGG					
FLEXWELL HL-40 (1.5 INCH)	30-3000	30-1100	No	33,000	0.092
FLEXIBLE PIPE - ENVIRON					
GEOFLEX D (1.5 INCH) ⁴	30-3000	30-1100	10-500	14,500 ⁴ (5700)	0.092
GEOFLEX D (2 INCH) ⁴	30-3000	30-650	No	11,000 ⁴ (4500)	0.163
GEOFLEX D (3 INCH)	30-3000	30-300	No	4100	0.367
GEOFLEX PLUS D (1.5 INCH)	30-3000	30-1100	10-500	16,500	0.092
FLEXIBLE PIPE - FLEXWORKS					
C15 (1.5 INCH)	30-3000	30-1100	10-500	14,500	0.092
C20 (2.0 INCH)	30-3000	30-650	No	11,000	0.163
C30 (3.0 INCH)	30-3000	30-300	No	4100	0.367
FLEXIBLE PIPE - FURON					
OPW PISCES - SINGLE WALL					
SP15 (1.5 INCH)	30-3000	30-1100	No	9000	0.092
SP20 (2 INCH)	30-3000	30-650	No	7000	0.163
OPW PISCES - DOUBLE WALL					
CP15 (1.5 INCH)	30-3000	10-1100	No	11,650	0.092
CP15DW (1.5 INCH)	30-3000	30-1100	No	5400	0.092
CP20 (2 INCH)	30-3000	30-650	No	7600	0.163
WESTERN FIBERGLASS - DOUBLE WALL					
COFLEX (1.5 INCH) ⁵	10-3000	10-1100	No	14,500 ⁵ (5400)	0.092
COFLEX (2 INCH) ⁵	30-3000	30-650	No	11,000 ⁵ (7600)	0.163
FLEXIBLE PIPE - NUPI					
SMARTFLEX					
SMARTFLEX (1.5 INCH)	20-3000	20-1100	No	8600	0.092
SMARTFLEX (2.0 INCH)	20-3000	20-650	No	15,000	0.163
T SMA - T SMAH - SINGLE WALL					
1.5 INCH	30-3000	30-1100	No	18100	0.092
2 INCH	30-3000	30-650	No	17200	0.163
3 INCH	30-3000	30-300	No	16200	0.367
T SMA X P - SINGLE WALL					
1.5 INCH	30-3000	30-1100	No	21500	0.092
2 INCH	30-3000	30-650	No	20700	0.163
3 INCH	30-3000	30-300	No	19400	0.367

Veeder-Root Line Leak Application Guide

PIPE TYPE	TLS-4XX w/ DPLLD ^{6,7} (Length Feet)	TLS-350 w/ PLLD ¹ (Length Feet)	TLS-350 w/ WPLLD ² (Length Feet)	BULK MODULUS ³ (PSI)	VOLUME (Gallons/Foot)
FLEXIBLE PIPE - NUPI (Continued)					
TSMAD - DOUBLE WALL					
1.5 INCH	30-3000	30-1100	No	18900	0.092
2 INCH	30-3000	30-650	No	12500	0.163
3 INCH	30-3000	30-300	No	28200	0.367
TSMAXPD - DOUBLE WALL					
1.5 INCH	30-3000	30-1100	No	15500	0.092
2 INCH	30-3000	30-650	No	9200	0.163
3 INCH	30-3000	30-300	No	27800	0.367
FLEXIBLE PIPE - PETROTECHNIK					
PETROTECHNIK UPP EXTRA (63 mm)	20-3000	20-650	No	11,500	0.163
FLEXIBLE PIPE - TOTAL CONTAINMENT					
ENVIROFLEX RETRACTABLE PIPE					
PP1500 (1.5 INCH)	10-3000	10-1100	10-500	2400	0.092
PP1501 (1.5 INCH)	10-3000	10-1100	10-500	3500	0.092
PP1502 (1.5 INCH)	10-3000	10-1100	No	7300	0.092
PP1503 (1.5 INCH)	10-3000	10-1100	No	2500	0.092
PP2500 AND PP2501 (2.5 INCH)	No	No	No	---	---
PP2502 (2.5 INCH)	10-3000	10-430	No	8700	0.255
PP2503 (2.5 INCH)	10-3000	10-430	No	3100	0.255
OMNIFLEX COAXIAL PIPE					
CP1501 (1.5 INCH)	10-3000	10-1100	10-500	13,000	0.092
CP1503 (1.5 INCH)	10-3000	10-1100	No	4500	0.092
CP2503 (2.5 INCH)	10-3000	20-430	No	3900	0.255
FLEXIBLE PIPE - DOUBLE TRAC (OMEGA FLEX)					
UGF-FSP-16 (1.0 INCH)	30-500	30-500	No	31,000	0.058
UGF-FSP-24 (1.5 INCH)	30-3000	30-1100	No	31,000	0.116
UGF-FSP-32 (2.0 INCH)	30-3000	30-650	No	31,000	0.204

¹Mixed Piping Types with PLLD: Using TLS-350 software Version 23 or later, PLLD is certified for 3 gph-only testing for line volumes up to 212 gallons; and for 0.2/0.1 gph testing for line volumes up to 110 gallons. To determine the line volume for mixed piping types, multiply the line length (in feet) times the 'gallons/foot' value for each pipe type and add the results. For example, site has 150 feet of 2" fiberglass and 50 feet of 3" fiberglass pipe:

$$\text{Total line volume} = [150 \times 0.204] + [50 \times 0.461] = 30.6 + 23.1 = 53.7 \text{ gallons}$$

²The 0.2 and 0.1 gph line leak tests cannot be run on flex piping with WPLLD.

³Bulk Modulus entry is only applicable to TLS-350 consoles w/software Version 23 or later and all TLS-450 Series consoles. Refer to TLS-350 System Setup manual (P/N 576013-623) or TLS-450 Setup Manual (P/N 576013-940) for programming instructions.

⁴Geoflex piping produced prior to 2001 has a lower bulk modulus than the current product. For this piping (pre-2001) use the values in (). For 2001 piping and later, you must set the correct Bulk Modulus in the "User Defined" menu.

⁵Western Fiberglass COFLEX piping produced prior to 2005 has a different bulk modulus than the current product. For piping produced prior to 2005, use the values in ().

⁶Line lengths shown represent DPLLD approved lengths for 3 gph and 0.2 gph testing. 3.0 gph and 0.2 gph testing for DPLLD with software version 7E or higher is certified for line volumes up to 1178.6 gallons (not to exceed 3000 feet of line). See footnote 1 for instructions on calculating line volume for mixed piping.

⁷0.1 gph testing is certified for line volumes up to 535.6 gallons (not to exceed 1100 feet of line). See footnote 1 for instructions on calculating line volume for mixed piping.

Specifications and Compatible Fluids Requirements

The table below lists Veeder-Root Line Leak Detector specifications.

SPECIFICATION	TLS-4XX w/ DPLLD	TLS-350 w/ PLLD	TLS-350 w/ WPLLD
OPERATING TEMP:	-25 TO +130°F	-25 TO +130°F	-25 TO +130°F
COMPATIBLE FUELS:	UNLEADED GASOLINE LEADED GASOLINE 5% METHANOL / 95% UNLEADED 0 - 100% ETHANOL 10% ETHANOL / 90% UNLEADED 15% MTBE / 85% UNLEADED DIESEL BIODIESEL (UP TO B100) ^{1,2} KEROSENE JET FUEL AVIATION GASOLINE	UNLEADED GASOLINE LEADED GASOLINE 5% METHANOL / 95% UNLEADED 0 - 100% ETHANOL 10% ETHANOL / 90% UNLEADED 15% MTBE / 85% UNLEADED DIESEL BIODIESEL (UP TO B100) ^{1,2} KEROSENE JET FUEL AVIATION GASOLINE	UNLEADED GASOLINE LEADED GASOLINE 5% METHANOL / 95% UNLEADED 10% ETHANOL / 90% UNLEADED 15% MTBE / 85% UNLEADED DIESEL BIODIESEL (UP TO B100) ^{1,2} KEROSENE JET FUEL AVIATION GASOLINE
LINE FLOW RATE:	120 GPM MAX. W/SWIFTCHECK VALVE	120 GPM MAX. W/SWIFTCHECK VALVE	120 GPM MAX. W/SWIFTCHECK VALVE
OPERATING RANGE:	0 - 70 PSI	0 - 70 PSI	0 - 70 PSI
PROOF PRESSURE:	200 PSI	200 PSI	200 PSI
MAX. VERTICAL PIPELINE HEIGHT ABOVE TRANSDUCER³	11 FEET	11 FEET	11 FEET
MINIMUM PUMP OUTPUT PRES-SURE⁴	23 psi	23 psi	23 psi

¹Biodiesel compliant with ASTM D7467 (up to B20) or ASTM D6751.

²Consult pump manufacturer for compatibility ratings on fuel blends greater than B20.

³Applications that exceed these max. vertical pipeline heights will require further consultation. Please contact Veeder-Root at 800-323-1799 (request a Veeder-Root/Red Jacket Application Engineer).

⁴Pump output pressure should be a minimum of 4 psi above the check valve's relief pressure.

Veeder-Root recommends that system software for the console be upgraded to the latest version when installing any new hardware. For TLS-350 Consoles, when installing latest software, PLLD or WPLLD must be specified and customer must upgrade to ECPU2 if not already installed. See Accessories/Upgrades section of price book or your local Veeder-Root authorized distributor for details.

Check Valve Requirements

DPLLD, PLLD and WPLLD require certain check valves or Pressurstat assemblies to be installed on the pump. Use of non-compatible check valves can result in loss of leak detection performance.

Supported Pumps	Check/Relief Valve Type	3.0 GPH Only Testing (Req'd. Kit)	3.0, 0.2, 0.1 GPH Testing (Req'd. Kit)	Additional Req'd. Parts for Manifoldded Lines (Single Tank w/ 2 STPs, or 2 or More Tanks w/ STP in Each)
DPLLD/PLLD Applications				
The Red Jacket	None Required	848480-001 (TLS-350) 859080-001 (TLS-4XX)	848480-001 (TLS-350) 859080-001 (TLS-4XX)	Check Valve for Each Slave Pump P/N 410153-002 (See illustration in Note 1 below)
Quantum (All Models) (See Note 2 below)	Red Jacket SpikeCheck Valve (Factory Installed)	848480-001 (TLS-350) 859080-001 (TLS-4XX)	848480-001 (TLS-350) 859080-001 (TLS-4XX)	Red Jacket Quantum SpikeCheck Valve, Non-PSI Relief Valve, Required for Each Slave Pump, P/N 388-081-5 (Field Installed Only)
	Red Jacket SpikeCheck Valve (Field Only Installed) P/N 388-080-5	848480-001 (TLS-350) 859080-001 (TLS-4XX)	848480-001 (TLS-350) 859080-001 (TLS-4XX)	
	Red Jacket Pressurstat Assembly.	848480-001 (TLS-350) 859080-001 (TLS-4XX)	----- Not supported -----	Non-Vented SwiftCheck Valve for Each Slave Pump kit, P/N 330020-416
Standard (All Models)	SwiftCheck	848480-003 (TLS-350) 859080-002 (TLS-4XX)	848480-003 (TLS-350) 859080-002 (TLS-4XX)	Non-Vented SwiftCheck Valve for Each Slave Pump kit, P/N 330020-416
	Red Jacket Functional Element Assembly	848480-001 (TLS-350) 859080-001 (TLS-4XX)	----- Not supported -----	
	Red Jacket SpikeCheck Valve (Field Installed Only) P/N 410557-001	848480-001 (TLS-350) 859080-001 (TLS-4XX)	848480-001 (TLS-350) 859080-001 (TLS-4XX)	Red Jacket Standard SpikeCheck Valve, Non-PSI Relief Valve, Required for Each Slave Pump, P/N 410557-002 (Field Installed Only)
Maxxum	None Required	848480-001 (TLS-350) 859080-001 (TLS-4XX)	848480-001 (TLS-350) 859080-001 (TLS-4XX)	See Note 4 below.
Big-Flo	Pressurstat Kit P/N 144-314-5		(See Note 3 below)	
FE Petro	FE Petro Model R P/N 400988932 and Replacement O-ring for the Valve Housing (See Note 4 below)	848480-001 (TLS-350) 859080-001 (TLS-4XX)	848480-001 (TLS-350) 859080-001 (TLS-4XX)	Non-Vented SwiftCheck Valve for Each Slave Pump kit, P/N 330020-416 --- OR --- FE Petro 65 psi Relief Check Valve (FE P/N 402459931) (See Note 5 below)
	FE Petro Model R Relief Valve P/N 401330902			
Tokheim & Bennett	SwiftCheck	848480-003 (TLS-350) 859080-002 (TLS-4XX)	848480-003 (TLS-350) 859080-002 (TLS-4XX)	Non-Vented SwiftCheck Valve for Each Slave Pump kit, P/N 330020-416
WPLLD Applications				
The Red Jacket	None Required	849490-006	849490-006	High Pressure Check Valve for Each Slave Pump, P/N 410153-002 (See illustration in Note 1 below)
Quantum (All Models) (See Note 2 below)	Red Jacket SpikeCheck Valve (Factory Installed)	849490-005 (Except CPT)	849490-005 (Except CPT)	Non-Vented SwiftCheck Valve for Each Slave Pump kit, P/N 330020-416
	Red Jacket Pressurstat Assembly	849490-005 (Except CPT)	----- Not supported -----	
Standard (All Models)	SwiftCheck	849490-002 (Except CPT)	849490-002 (Except CPT)	
	Red Jacket Functional Element Assembly	849490-003 (Except CPT)	----- Not supported -----	
FE Petro	FE Petro Model R P/N 400988932 and Replacement O-ring for the Valve Housing (See Note 5 below)	849490-001	849490-001	Non-Vented SwiftCheck Valve for Each Slave Pump kit, P/N 330020-416 --- OR --- FE Petro 65 psi Relief Check Valve (FE P/N 402459931) (See Note 5 below)

NOTES:

- The Veeder-Root High Pressure Check Valve (P/N 410153-002) is shown below:

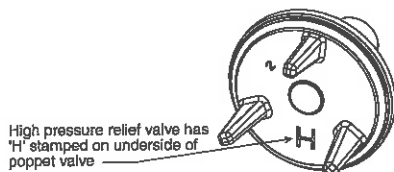

- For Red Jacket Quantum pumps, the SpikeCheck is the preferred check valve type.
- 0.2/0.1 gph testing is supported for the Maxxum pump, but you must select 'User Defined' as the pipe type during DPLLD or PLLD setup.
- If maximum pump pressure is NOT a minimum of 5 psi below the pressurstat relief setting, then a check valve must be installed in the discharge line of the slave pump (see "Manifoldded Line Applications" on page 12).
- Veeder-Root does not warrant the performance of FE Petro's Model 'R' check valve or 65 psi relief check valve.

TLS-450PLUS and TLS-450 Series Consoles - DPLLD

Hardware Required for DPLLD Leak Detection

DIGITAL PRESSURIZED LINE LEAK DETECTOR (DPLLD) - Order one per line.

MODEL NO.	ITEM
859080-001	PRESSURIZED LINE LEAK DETECTOR WITHOUT SWIFTCHECK VALVE
859080-002	PRESSURIZED LINE LEAK DETECTOR WITH SWIFTCHECK VALVE

DPLLD MODULES

- One Universal Sensor Module is required per console. One USM module monitors up to 16 lines.
- One Input/Output Module is required per console. One I/O module monitors up to 5 lines.

MODEL NO.	ITEM
332812-001	UNIVERSAL SENSOR MODULE
332813-001	INPUT/OUTPUT MODULE

DPLLD Leak Test Options

TESTING	TLS-450	TLS-450PLUS
ULTIMATE TESTING	332972-007	332972-007
RISK MANAGEMENT	332972-008	332972-008
BASE COMPLIANCE	332972-009	332972-009
3 GPH	332972-999	Included

DPLLD Precision Testing Frequencies

ON-DEMAND (D)

Testing can be initiated manually through the TLS Console.

AUTO (A)

Tests will run repetitively until a passing test is achieved. Once a passing test is achieved, testing will stop and recommence six months from the date of the last passing test.

MONTHLY (M)

Tests will run repetitively until a passing test is achieved. Once a passing test is achieved, testing will stop and recommence the first calendar day of the next month.

REPETITIVE (R)

Tests will run repetitively according to pre-programmed time intervals.

Refer to the matrix below to determine which precision testing option best meets your needs:

TESTING OPTION	0.2 GPH TESTS	0.1 GPH TESTS
ULTIMATE TESTING	D, M, R	D, A, R
RISK MANAGEMENT	D, M, R	D, A
BASE COMPLIANCE	None	D, A

DPLLD Accessories and Spare Parts

The following DPLLD accessories and spare parts are available:

MODEL NO.	ITEM
331014-001	SWIFTCHECK VALVE (INSTALLS IN THE PUMP'S MECHANICAL LEAK DETECTOR PORT)
330020-619	UNIVERSAL PROBE/SENSOR INTERFACE MODULE
330020-620	UNIVERSAL INPUT/OUTPUT INTERFACE MODULE
330020-416	NON-VENTED SWIFTCHECK
410153-002	KIT-CHECK VALVE-HIGH
410557-001	KIT-CHECK/RELIEF VALVE
410557-002	KIT-CHECK/RELIEF VALVE-NON RELIEF

TLS-350 Consoles - PLLD

Hardware Required for PLLD Leak Detection

PRESSURIZED LINE LEAK DETECTOR (PLLD)

Order one per line.

MODEL NO.	ITEM
848480-003	PRESSURIZED LINE LEAK DETECTOR WITH SWIFTCHECK VALVE
848480-001	PRESSURIZED LINE LEAK DETECTOR WITHOUT SWIFTCHECK VALVE

PLLD MODULES

•TLS-350/TLS-350 Plus/TLS-350R Consoles - Leak Detection for up to 6 Lines

One Pressurized Line Leak Detector Interface Module is required per console. Order PLLD Controller modules as required - one Controller module monitors up to 3 lines.

MODEL NO.	ITEM
330843-001	SIX INPUT PRESSURIZED LINE LEAK INTERFACE MODULE (MAXIMUM 1 PER CONSOLE)
330374-001	PRESSURIZED LINE LEAK CONTROLLER MODULE (MAXIMUM 2 PER CONSOLE)

•TLS-350J Consoles - Leak Detection for up to 4 Lines

One 'J' PLLD Interface Module is required per console. Order PLLD Controller modules as required - one Controller module monitors up to 3 lines.

MODEL NO.	ITEM
330843-002	'J' PLLD INTERFACE MODULE (MAXIMUM 1 PER CONSOLE)
330374-001	PRESSURIZED LINE LEAK CONTROLLER MODULE (MAXIMUM 2 PER CONSOLE)

PLLD PRECISION TESTING SOFTWARE MODULE

Precision line leak detection capability (0.2 gph / 0.1 gph) requires one SEM (Software Enhancement Module) for the console that must be ordered separately from the table below. Not required for 3.0 gph-only line leak detection capability.

TESTING OPTION	TLS-350/TLS-350J/ TLS-350PLUS/TLS-350R WITHOUT BIR (SEM P/N)	TLS-350R WITH BIR (SEM P/N)
ULTIMATE TESTING	330160-010	330160-110
RISK MANAGEMENT	330160-060	330160-160
BASE COMPLIANCE	330160-050	330160-150
3.0 GPH	INCLUDED*	INCLUDED*

*A SEM is not required for 3 GPH-only testing.

PLLD Precision Testing Frequencies

ON-DEMAND (D)

Testing can be initiated manually through the TLS Console.

AUTO (A)

Tests will run repetitively until a passing test is achieved. Once a passing test is achieved, testing will stop and recommence six months from the date of the last passing test.

MONTHLY (M)

Tests will run repetitively until a passing test is achieved. Once a passing test is achieved, testing will stop and recommence the first calendar day of the next month.

REPETITIVE (R)

Tests will run repetitively according to pre-programmed time intervals.

Refer to the matrix below to determine which precision testing option best meets your needs:

TESTING OPTION	0.2 GPH TESTS	0.1 GPH TESTS
ULTIMATE TESTING	D, M, R	D, A, R
RISK MANAGEMENT	D, M, R	D, A
BASE COMPLIANCE	None	D, A

PLLD Accessories and Spare Parts

The following PLLD accessories and spare parts are available:

MODEL NO.	ITEM
331014-001	SWIFTCHECK VALVE (INSTALLS IN THE PUMP'S MECHANICAL LEAK DETECTOR PORT)
847490-109	SIX INPUT PLLD INTERFACE MODULE (THROUGH-HOLE MOUNT) - REPLACEMENT ONLY
847490-110	SIX INPUT PLLD INTERFACE MODULE (SURFACE MOUNT)
330020-416	NON-VENTED SWIFTCHECK
410153-002	KIT-CHECK VALVE-HIGH
410557-001	KIT-CHECK/RELIEF VALVE
410557-002	KIT-CHECK/RELIEF VALVE-NON RELIEF

Note:

The through-hole mount, six input PLLD Interface Module (P/N 847490-109) is for repair/replacement in existing consoles only. Spare 847490-109 modules are shipped with complete installation and programming instructions and not pre-installed in consoles. Customers that require replacement of PLLD Interface Modules should replace like for like, i.e. through-hole mount PLLD Interface Modules for through-hole mount PLLD Interface Modules. Surface mount PLLD Interface Modules are NOT interchangeable with through-hole mount PLLD Interface Modules.

TLS-350 Consoles - WPLLD

Hardware Required for Wireless Pressurized Line Leak Detection (WPLLD)

WIRELESS PRESSURIZED LINE LEAK DETECTOR (WPLLD)

Order one per line.

MODEL NO.	ITEM
849490-001	WPLLD KIT - FOR FE PETRO PUMPS ¹
849490-002	WPLLD KIT WITH SWIFTCHECK VALVE - FOR RED JACKET PUMPS (EXCLUDING QUANTUM) ²
849490-003	WPLLD KIT - 3 GPH ON RED JACKET PUMPS (EXCLUDING QUANTUM) ³
849490-004	WPLLD KIT W/O SWIFTCHECK VALVE FOR RED JACKET PUMPS (EXCLUDING QUANTUM)
849490-005	WPLLD KIT - FOR RED JACKET QUANTUM PUMPS ⁴
849490-006	WPLLD KIT - FOR THE RED JACKET PUMP

¹Contains Line Leak Sensor, and installation kit for FE Petro pumps. Requires FE Petro Model R Check Valve, P/N 400988932.

²Contains Line Leak Sensor, SwiftCheck valve, and installation kit for Red Jacket pumps.

³Supports 3 GPH testing only. Contains Line Leak Sensor, and installation kit for Red Jacket pumps. Requires Red Jacket's Functional Element Assembly models 323-001-5 or 323-002-5. Does not support precision (0.2 GPH or 0.1 GPH) line testing.

⁴Contains Line Leak Sensor and Installation kit for Red Jacket Quantum pumps. Requires purchase of SpikeCheck valve, P/N 388-080-5, from Red Jacket.

WPLLD MODULES

One of each module from the table below is required. Order additional WPLLD Controller modules (P/N 330841-001) as required - each Controller module monitors up to 3 lines.

MODEL NO.	ITEM
330874-001	WPLLD AC INTERFACE MODULE (MAXIMUM 1 PER CONSOLE)
330883-001	COMMUNICATIONS MODULE (MAXIMUM 1 PER CONSOLE)
330841-001	WPLLD CONTROLLER MODULE (MAXIMUM 3 PER CONSOLE*)

*Maximum of 2 WPLLD Controller module per TLS-350J console

WPLLD PRECISION TESTING SOFTWARE MODULE

Precision line leak detection capability (0.2 gph / 0.1 gph) requires one SEM (Software Enhancement Module) for the console that must be ordered separately from the table below. Not required for 3.0 gph-only line leak detection capability.

TESTING OPTION	TLS-350 / TLS-350J / TLS-350PLUS / TLS-350R (W/O BIR) (SEM P/N)	TLS-350R (WITH BIR) (SEM P/N)
ULTIMATE TESTING	330160-010	330160-110
RISK MANAGEMENT	330160-060	330160-160
BASE COMPLIANCE	330160-050	330160-150
3.0 GPH	INCLUDED*	INCLUDED*

*A SEM not required for 3 gph testing.

WPLLD Precision Testing Frequencies

ON-DEMAND (D)

Testing can be initiated manually through the TLS Console.

AUTO (A)

Tests will run repetitively until a passing test is achieved. Once a passing test is achieved, testing will stop and recommence six months from the date of the last passing test.

MONTHLY (M)

Tests will run repetitively until a passing test is achieved. Once a passing test is achieved, testing will stop and recommence the first calendar day of the next month.

REPETITIVE (R)

Tests will run repetitively according to pre-programmed time intervals.

Refer to the matrix below to determine which precision testing option best meets your needs:

TESTING OPTION	0.2 GPH TESTS	0.1 GPH TESTS
ULTIMATE TESTING	D, M, R	D, A, R
RISK MANAGEMENT	D, M, R	D, A
BASE COMPLIANCE	NONE	D, A

WPLLD Accessories & Spare Parts

The following WPLLD accessories and spare parts are available:

MODEL NO.	ITEM
330020-290	WIRELESS REPLACEMENT TRANSDUCER FOR RED JACKET PUMPS
330020-291	WIRELESS REPLACEMENT TRANSDUCER FOR FE PETRO PUMPS
330773-001	SWIFTCHECK VALVE FOR WPLLD
330841-001	WPLLD CONTROLLER MODULE
330874-001	WPLLD AC INTERFACE MODULE
330883-001	WPLLD COMMUNICATIONS MODULE
330020-416	NON-VENTED SWIFTCHECK
330770-001	WPLLD SENSING LINE FOR FE PETRO PUMPS
330772-001	WPLLD SENSING LINE FOR RED JACKET PUMPS W/ SWIFTCHECK
331069-001	WPLLD SENSING LINE FOR RED JACKET STANDARD PUMPS W/O SWIFTCHECK
410138-001	WPLLD SENSING LINE FOR THE RED JACKET STANDARD PUMPS W/O SWIFTCHECK
330020-412	WPLLD INSTALLATION ADAPTOR KIT FOR RED JACKET QUANTUM PUMPS
330020-477	WPLLD INSTALLATION ADAPTOR KIT FOR RED JACKET PUMPS
330020-096	WPLLD INSTALLATION ADAPTOR KIT FOR FE PETRO PUMPS

Special Installations

Manifolded Line Applications

DPLLD, PLLD and WPLLD leak detection systems can handle product lines supplied by multiple tanks and pumps, to a maximum of 8 tanks and pumps per product line.

Standard line leak sensing and check valve equipment should be installed at the primary pump.

To perform 0.2 and 0.1 gph tests, a non-vented SwiftCheck valve (P/N 330020-416), or new Red Jacket 65 psi relief valve (P/N 410153-002), or SpikeCheck Valve Non-PSI Relief Valve for Standard Pump (P/N 410557-002), or FE Petro 65 psi Relief Check Valve (FE P/N 402459931) should be installed on each of the other pumps supporting the manifolded product line. The Non-Vented SwiftCheck Valve is rated to a maximum 70 gpm.

NOTICE For 5 HP Maxxum pumps in diesel, an additional in-line check valve with no pressure relief should be installed on the 'Slave' pump to prevent backflow.

A relay on a Four-Relay module or I/O Combination module (TLS-350 Series) or I/O Module (TLS-450 Series) must be available to control each secondary pump. The standard line leak modules will provide pump control output for the primary pump and the "Pump In" signal for the set.

A typical manifolded line installation for DPLLD and PLLD is shown below:

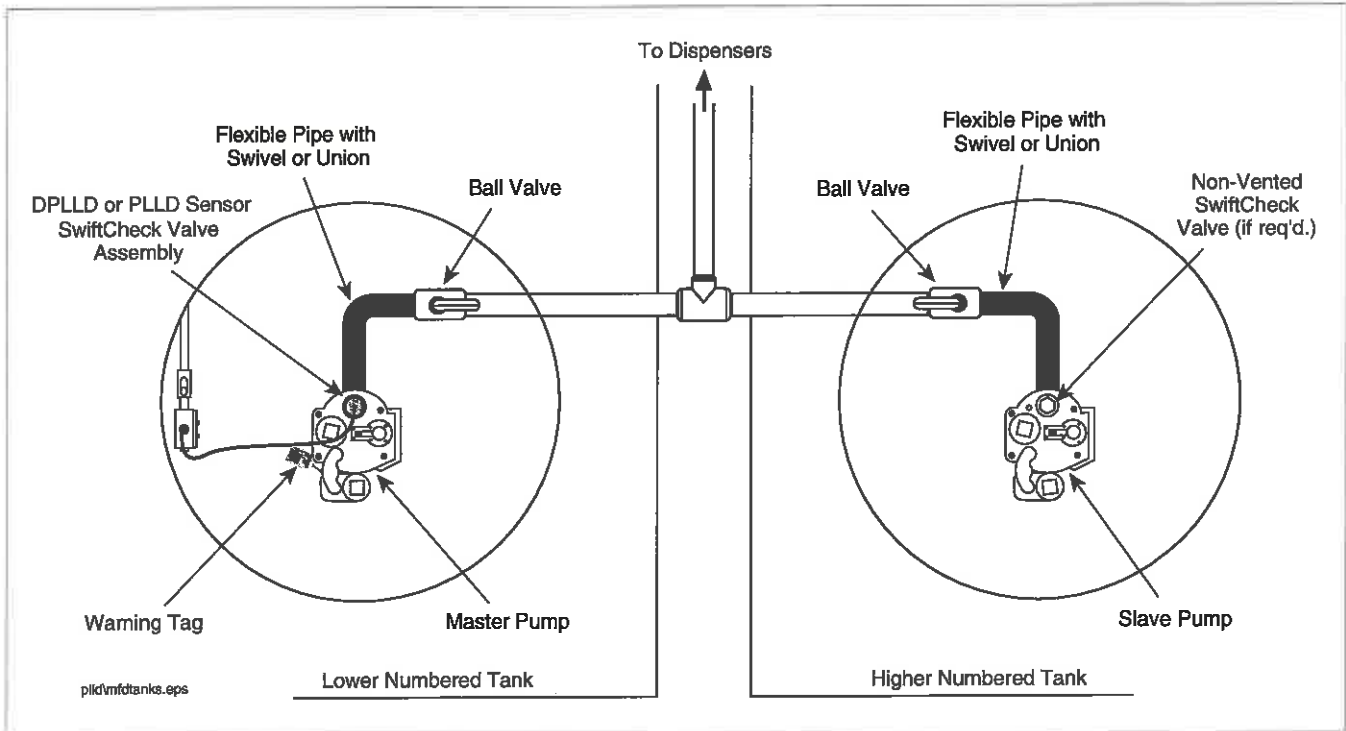

Transducer Installation - Red Jacket CPT and Quantum CPT Pumps

This installation procedure is to be used with Red Jacket CPT and Quantum CPT Pumps.

1. Install the Red Jacket CPT Transducer Adapter Kit (Red Jacket part number 144-326-5) following the instructions with the kit. Thread the PLLD transducer in the mechanical LLD port of the pump.

NOTICE Seal any pipe threads using a UL-classified, nontoxic pipe sealant suitable for the fuel involved.

The figure below illustrates two DPLLD and PLLD transducer installations in Red Jacket CPT pumps - consult "Check Valve Requirements" on page 6, to determine what check valve you will need to install to perform your intended level of testing.

2. Verify that the TLS-350 Series Console has Version x19 or later (TLS-450 Series Console has Version 1 or later) software.
3. Verify that the CPT Controller has Version 1.02 or later software installed.

4. Locate red switch bank labeled **S1** on the CPT's Controller CPU board, and verify that dip switch 2 is set to the **Closed** position (to enable the PLLD precision line leak function), and dip switch 8 is set to the **Open** position (to disable the CPT's line leak function).
5. Verify that the Rotary Pressure Dial, also on the CPT's Controller CPU board, is set to either the 2 (24 psi), 3 (27 psi), 4 (30 psi), 5 (33 psi), or 6 (36 psi) position.

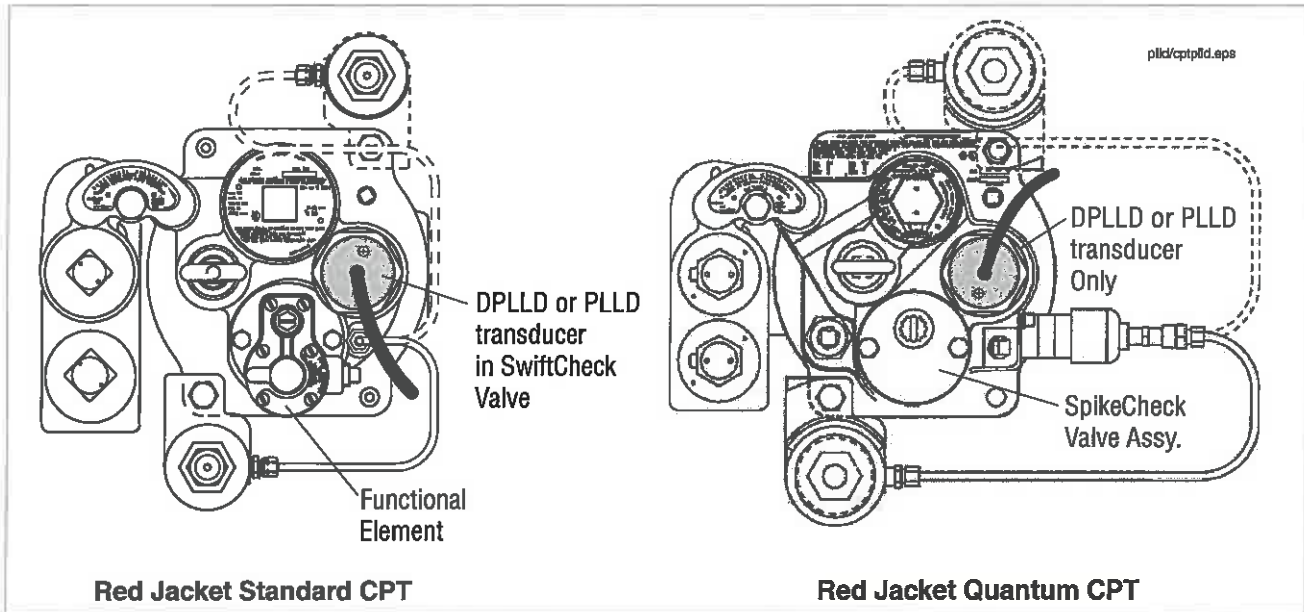

Transducer Installation - Red Jacket Big-Flo Pumps, Red Jacket Maxxum Pumps and FE Petro High Capacity Pumps

BIG-FLO PUMPS

1. You will need to install a reducing tee (customer supplied) in either of the 3-inch discharge ports of the pump with the 2-inch opening facing up. If you have the room, it may be easier to install this tee between the Pressurstat kit and the unused port instead of in the discharge line (as shown in the figure below). Alternatively, the DPLLD or PLLD transducer can be installed in the leak detector port of a Big-Flo leak detector if it is already present in the line (as shown in the figure below).
2. Install the Red Jacket Big-Flo Pressurstat Kit (Red Jacket part number 144-314-5) following the instructions with the kit.
3. Thread the DPLLD or PLLD transducer into the 2-inch opening of the tee.

NOTICE Seal any pipe threads using a **UL-classified, nontoxic pipe sealant suitable for the fuel involved.**

4. Verify that the TLS-350 Series Console has Version x19 or later (TLS-450 Series Console has Version 1 or later) software.

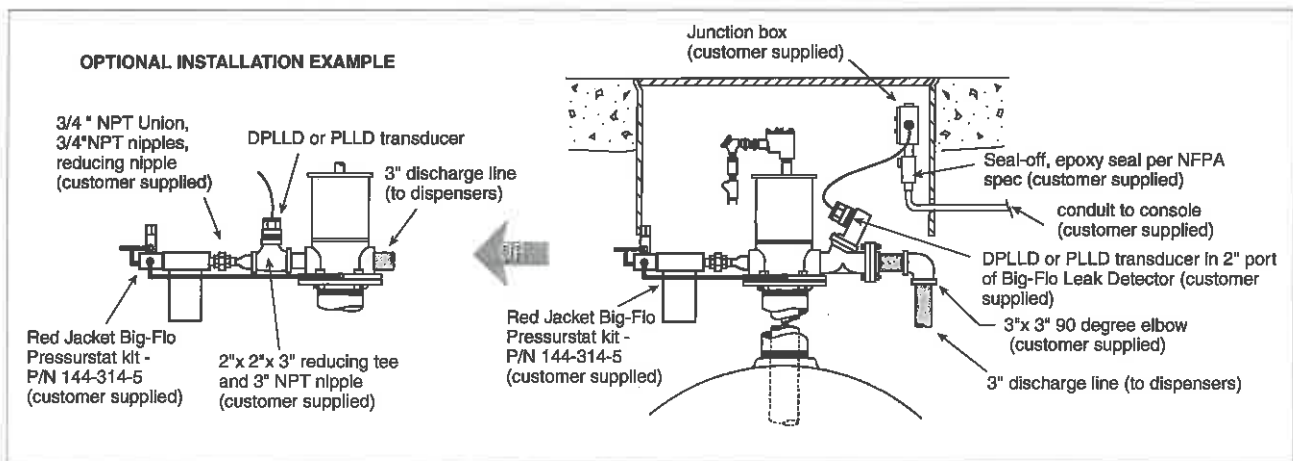

MAXXUM PUMPS

1. Thread the DPLLD or PLLD transducer into the 2-inch opening of the transducer port.

NOTICE Seal any pipe threads using a UL-classified, nontoxic pipe sealant suitable for the fuel involved.

2. If any in-line check valves or a Big-Flo Diaphragm Valve are installed in the line, they must be removed.
3. Verify that the TLS 350 Series Console has Version x19 or later software (TLS-450 Series Consoles Version 1 or later software).

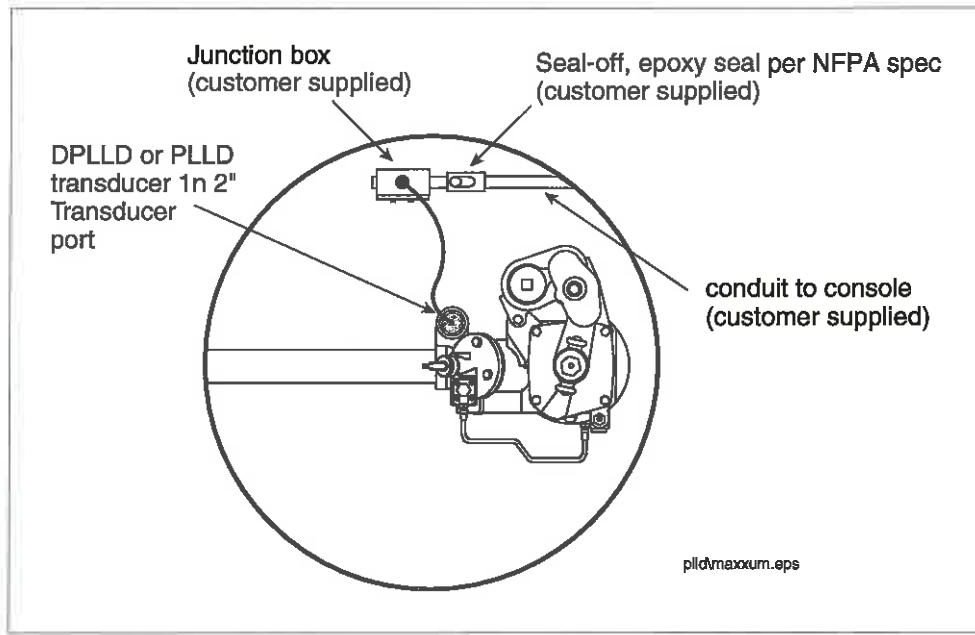

FE PETRO HIGH CAPACITY PUMPS

1. Install a reducing tee (customer supplied) in either of the 3-inch discharge ports of the pump with the 2-inch port facing up.
2. Thread the D/PLLD transducer into the 2-inch port on the tee fitting.

NOTICE Seal any pipe threads using a UL-classified, nontoxic pipe sealant suitable for the fuel involved.

3. Install a model "R" relief valve into the pump if one is not already present.

