

DEFENDER SERIES® OVERFILL PREVENTION VALVE

The Defender Series® Overfill Prevention Valve (OPV) prevents the overfill of an underground storage tank during a gravity-fed product delivery. It employs a revolutionary magnetically-coupled actuator system to provide positive shutoff. This unique method of shutoff eliminates any penetrations in the valve, making it both vapor and leak tight. This also allows for remote compliance testing of the primary functionality at grade level without having to remove the OPV from the tank.



Drop Tube
Adapter

HIGHLIGHTS

- Magnetic coupler actuates the interior primary flapper assembly and secondary shut-off valve when the float rises outside of the valve, eliminating valve body penetrations and any potential product or vapor leak points.
- After cutting to length in the field, the upper drop tube is roll-crimped onto a top adapter outfitted with two O-rings and then threaded onto the top of the valve body, eliminating the need for drilling, rivets, epoxy, and flaring tools.
- Bottom drop tube is cut in the field and threaded onto the bottom of the valve ensuring straight installation.
- The roll-crimp/thread method of installing drop tubes ensures proper alignment of the drop tubes with the rest of the OPV assembly, making installation and removal of the entire assembly smooth.
- Damaged drop tubes can be easily replaced instead of having to purchase an entire new assembly.
- Fully compatible with gas, gas/alcohol blends, diesel, and Biodiesel.
- Compatible with industry standard 4" drop tubes allowing retrofit into existing installations.
- The entire OPV assembly remains within the 4" inner diameter of the riser preventing interference with other tank components and also allowing removal even while the tank is full.
- Actuates in both low- and high-flow applications and functions within a broad range of flow rates from 25 gpm to 370 gpm (95 lpm to 1,400 lpm) and higher.
- The remote testing tool allows for remote testing of the primary functionality without having to remove the OPV from the riser.

SPECIFICATIONS

Approvals & Certifications

- CARB certified, VR-101-U (FFS) and VR-102 (OPW®).
- ATEX 2014/34/EU approved.
- EN13616 certified.
- KIWA BRL-K636/03 certified.
- UL 2583 listed and ULc listed, MH21090.
- For all vapor control and liquid control products covered by UL 2583 automotive fuels, only those fuels formulated in accordance with 40CFR80, "Regulation of Fuels and Fuel Additives," and meeting the following ASTM fuel specifications and blend limits:
 - ASTM D975 diesel with or without biodiesel blends up to 5% (B5)
 - ASTM D7467 diesel with biodiesel blends between 6% - 20% (B6 - B20)
 - ASTM D4814 gasoline with ethanol blends up to 10% (E10)
 - ASTM D4814 and ASTM D5798 mid-range ethanol/gasoline blends of (E11-50)
 - ASTM D5798 high-range ethanol/gasoline blends (E51-83)-Commercially sold as E85
 - Isobutanol Fuel Blends (max iBu16) of ASTM D4814 Gasoline (E0) and ASTM D7862 Butanol (2-methyl-1-propanol isomer)
- Alcohol, gas, biofuel compatible (E-85, gasoline and biodiesel) models come with hard coated anodized drop tubes for full compatibility.

SPECIFICATIONS CONTINUED

Dimensions

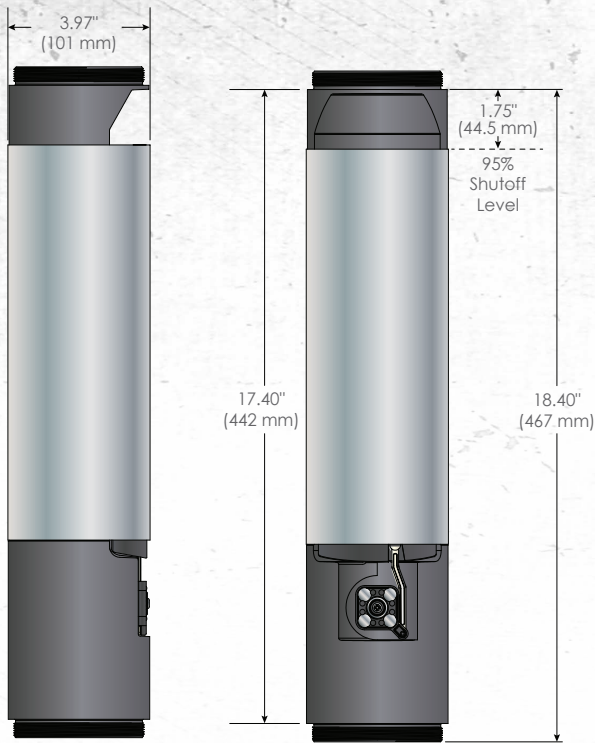

Components

- 1 Pre-flanged aluminum top drop tube
- 2 Roll-crimped top fitting/drop tube
- 3 Protective float sleeve
- 4 Float (shielded by float sleeve)
- 5 Valve assembly
- 6 Magnetically-coupled actuator
- 7 Threaded bottom drop tube

Operation

As the liquid level in the UST approaches 95% capacity, the liquid level raises the float. As the float rises it actuates the external/internal magnetic couplers which release the flapper to be closed by the flow of product. As the float continues to rise, the internal mechanism pushes the flapper further into the product flow to allow actuation at high or low flow rates. This sudden reduction in flow caused by the primary flapper closing creates “line shock” to the fill hose which signals the delivery driver that the tank is nearing 95% capacity. As the float continues to rise to the 95% fill level, the secondary closes, completely stopping the flow of fuel.

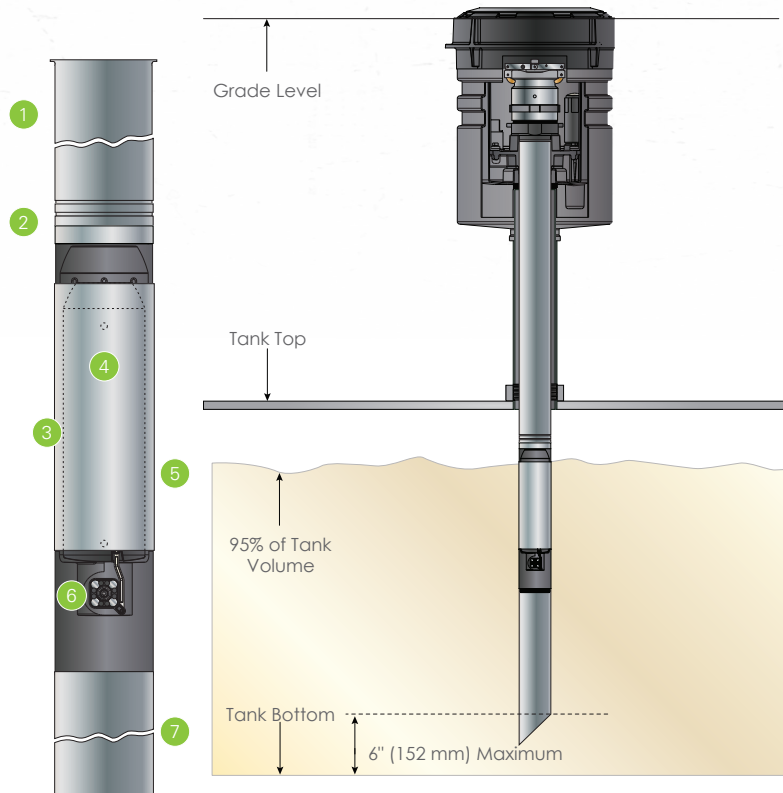

ORDERING INFORMATION

Model	Description
708691901	Defender Series® overfill prevention valve with 5' (1524 mm) top drop tube, 8' (2438 mm) bottom drop tube
708691902	Defender Series® overfill prevention valve with 5' (1524 mm) top drop tube, 10' (3048 mm) bottom drop tube
708691921	Defender Series® overfill prevention valve with 5' (1524 mm) top drop tube, 8' (2438 mm) bottom drop tube, AGB compatible*
708691922	Defender Series® overfill prevention valve with 5' (1524 mm) top drop tube, 10' (3048 mm) bottom drop tube, AGB compatible*
708692901	Defender Series® overfill prevention valve with 10' (3048 mm) top drop tube, 8' (2438 mm) bottom drop tube
708692902	Defender Series® overfill prevention valve with 10' (3048 mm) top drop tube, 10' (3048 mm) bottom drop tube
708692921	Defender Series® overfill prevention valve with 10' (3048 mm) top drop tube, 8' (2438 mm) bottom drop tube, AGB compatible*
708692922	Defender Series® overfill prevention valve with 10' (3048 mm) top drop tube, 10' (3048 mm) bottom drop tube, AGB compatible*
708693901	Defender Series® overfill prevention valve, coaxial with 6.5' (1981 mm) top drop tube, 8' (2438 mm) bottom drop tube
708693902	Defender Series® overfill prevention valve, coaxial with 6.5' (1981 mm) top drop tube, 10' (3048 mm) bottom drop tube
708693923	Defender Series® overfill prevention valve, poppeted coaxial with 6.5' (1981 mm) top drop tube, 8' (2438 mm) bottom drop tube, AGB compatible*
708693924	Defender Series® overfill prevention valve, poppeted coaxial with 6.5' (1981 mm) top drop tube, 10' (3048 mm) bottom drop tube, AGB compatible*
708694901	Defender Series® overfill prevention valve only with top adapter, AGB compatible*
708694902	Defender Series® overfill prevention valve only with coaxial top adapter, AGB compatible*
708535901	Roll crimping tool
708530930	Replacement roll crimper tool roller bit for retrofit with existing tool
708534901	Remote testing tool, 11' (3353 mm) long sectional/collapsible
708534902	Coaxial remote testing tool, 11' (3353 mm) long sectional/collapsible

*Alcohol, gas, biofuel compatible (E-85, gasoline and Biodiesel) models come with hard coated anodized drop tubes for full compatibility.

Replacement Parts

Model	Description
85039-DT	Spare drop tube seal
1103942	Spare adapter O-ring
1103943	Spare Coaxial adapter O-ring
708526901	Upper tube adapter kit
708529901	Coaxial Upper tube adapter kit

Model	Description
70821705	5' flanged top drop tube; order in multiples of 4
70821725	5' flanged top drop tube, AGB compatible; order in multiples of 4
708542908	8' thread-on bottom drop tube assembly, 2-pk
708542908AN	8' thread-on bottom drop tube assembly, 2-pk, AGB compatible
708542910	10' thread-on bottom drop tube assembly, 2-pk
708542910AN	10' thread-on bottom drop tube assembly, 2-pk, AGB compatible