



UST SYSTEM COMPONENTS	DOCUMENTATION DEMONSTRATING COMPATIBILITY WITH SUBSTANCE LISTED ABOVE		METHOD A or B (MAY USE BOTH)	DESCRIPTION OF COMPONENT TYPE, MODEL NUMBER, & NATIONAL LABORATORY CERTIFICATION, LISTING OR MANUFACTURER APPROVAL (ATTACH TO CHECKLIST)
RELEASE DETECTION EQUIPMENT	NO	YES		
SPILL PREVENTION EQUIPMENT	NO	YES		
OVERFILL PREVENTION EQUIPMENT	NO	YES		
GASKETS & SEALS (installs after 10/13/18)	NO	YES		
JOINT DOPES & ADHESIVES (installs after 10/13/18)	NO	YES		

**Methods:**

- A. Certification or listing of UST system equipment or components by a nationally recognized, independent testing laboratory for use with the regulated substance stored.
- B. Equipment or manufacturer approval. The manufacturer's approval must be in writing, indicate an affirmative statement of compatibility, specify the range of biofuel blends the component is compatible with, and be from the equipment or component manufacturer

Note: Owners and operators may find American Petroleum Institute's Recommended Practice 1626, *Storing and Handling Ethanol and Gasoline-Ethanol Blends at Distribution Terminals and Filling Stations*, useful in complying with the compatibility requirements.

In order to be in compliance with the 2015 federal UST regulation compatibility requirements for storing biofuels, you must keep documentation of compatibility of the UST system components listed on this page as long as you store the fuel.

For your records, you should update this checklist each time you repair or replace components of your UST system to ensure you have all the required compatibility documentation while storing biofuels.

Checklist Completed By:      print name: \_\_\_\_\_      date completed: \_\_\_\_\_  
signature: \_\_\_\_\_      position/title: \_\_\_\_\_

## LIMITED WARRANTY

### Underground Petroleum Storage Tanks

Xerxes Corporation ("Xerxes") warrants to owner ("Owner") that our underground petroleum storage tanks, if installed, used, and maintained in the United States or Canada in accordance with Xerxes' published specifications, installation instructions and operating guidelines, applicable supplemental materials, all applicable laws and regulations, and limited to storage of the products listed below at ambient temperatures or fuel oils, used in oil burning equipment, at temperatures not to exceed 150°F (65° C):

- 1) Will not fail for a period of thirty (30) years from date of original delivery by Xerxes due to natural external corrosion.
- 2) Will not fail for a period of thirty (30) years from date of original delivery by Xerxes due to internal corrosion, provided the tank is used solely, with or without tank water bottoms, to store the following products:
  - a. gasoline, jet fuel, aviation fuels, motor oils, motor vehicle waste oils, kerosene, diesel fuel, or fuel oils
    - gasoline with up to 20%, by volume, of methyl tertiary butyl ether (MTBE), ethyl tertiary butyl ether (ETBE), di-isopropyl ether (DIPE), tertiary butyl alcohol (TBA), tertiary amyl methyl ether (TAME), or tertiary amyl ethyl ether (TAEE)
  - b. **gasoline and ethanol blended motor fuels (per applicable ASTM fuel standards)**
    - **E10 (90% gasoline and 10% ethanol)**
    - **E15 (85% gasoline and 15% ethanol)**
    - **E85 (85% ethanol and 15% gasoline)**
    - **other ethanol blends up to and including 100% ethanol**
  - c. gasoline and methanol blended motor fuels (per applicable ASTM fuel standards)
    - M85 (85% methanol and 15% gasoline)
    - other methanol blends up to and including 100% methanol
    - Oxinol-50 waiver (90.5% gasoline and 9.5% Oxinol-50 comprised of a 4.75% methanol and 4.75% gasoline-grade tertiary butyl alcohol (GTBA) mixture)
    - Dupont EPA waiver (gasoline with 5% methanol and a minimum of 2.5% cosolvent – the blend may contain a maximum concentration of up to 3.7%, by weight, oxygen in the final fuel)
  - d. biodiesel fuel blends up to 100% biodiesel (per applicable ASTM fuel standards)
- 3) Will not fail for a period of thirty (30) years from date of original delivery by Xerxes due to structural failure (defined as spontaneous breaking or collapse caused by material defects in materials or workmanship).
- 4) Will meet Xerxes' published specifications and will be free of material defects in materials and workmanship for a period of one (1) year following the date of original delivery by Xerxes.

Xerxes warrants to Owner that all Xerxes-manufactured tank accessories, if installed, used and maintained in Canada or the United States in accordance with Xerxes' published specifications, installation instructions and operating guidelines, applicable supplemental materials, and all applicable laws and regulations, will be free of material defects in materials and workmanship for a period of one (1) year following the date of original delivery by Xerxes.

If any tank or accessory is to be removed from an installation, moved and reinstalled at Owner's new location and is intended for active service at the new location, the tank and accessories must be recertified by Xerxes to continue the balance of the limited warranty as originally extended.

The foregoing limited warranty does not extend to tanks or accessories ("individually and collectively Goods") damaged due to acts of God, war, terrorism, or failure of Goods caused, in whole or in part, by misuse, unlawful use, improper installation, storage, servicing or maintenance, or operation in excess of their rated capacity or contrary to their recommended use, whether intentional or otherwise, or any other cause or damage of any kind not the fault of Xerxes. Xerxes only warrants repairs or alterations performed by Xerxes or its authorized contractors performing work authorized in advance, in writing, by Xerxes. Xerxes does not warrant any product, components or parts manufactured by others. All consumable components including but not limited to o-rings and gaskets are excluded from this limited warranty.

Owner's sole and exclusive remedy for breach of warranty is limited at Xerxes' option to: (a) repair of the defective tank or accessory, (b) delivery of a replacement tank or accessory to the point of original delivery, or (c) refund of the original purchase price. No warranty claim will be considered without removing the tank and any accessory from the ground if Xerxes deems it necessary to evaluate a warranty claim. In the event of a breach of warranty claim, a claimant must give Xerxes the opportunity to observe and inspect the installation prior to the removal of any backfill below the tank top, and the removal of the tank and any accessory from the ground, or the claim will be forever barred. All claims must be made in writing within one (1) year after tank or accessory failure or be forever barred. ALL RIGHTS, OBLIGATIONS AND CLAIMS UNDER THIS LIMITED WARRANTY SHALL BE EXCLUSIVELY MADE AND DETERMINED IN THE COURTS OF, AND GOVERNED BY THE LAWS OF, THE STATE OF MINNESOTA, U.S.A., EXCLUDING ITS CONFLICT OF LAW PRINCIPLES.

THE FOREGOING WARRANTY CONSTITUTES XERXES' EXCLUSIVE OBLIGATION AND XERXES MAKES NO OTHER WARRANTY OR REPRESENTATION, EXPRESS OR IMPLIED, WITH RESPECT TO THE GOODS, OR ANY SERVICE, ADVICE, OR CONSULTATION, IF ANY, FURNISHED TO OWNER BY XERXES OR ITS REPRESENTATIVES, WHETHER AS TO MERCHANTABILITY, FITNESS FOR A PARTICULAR PURPOSE, OR OTHERWISE. THE SELLER (XERXES) UNDERTAKES NO RESPONSIBILITY FOR THE QUALITY OF THE GOODS, EXCEPT AS OTHERWISE PROVIDED IN THIS CONTRACT. THE SELLER (XERXES) ASSUMES NO RESPONSIBILITY THAT THE GOODS WILL BE FIT FOR ANY PARTICULAR PURPOSE FOR WHICH YOU (OWNER) MAY BE BUYING THESE GOODS, EXCEPT AS OTHERWISE PROVIDED IN THE CONTRACT. THE REMEDIES SET FORTH IN THE ABOVE WARRANTY ARE THE ONLY REMEDIES AVAILABLE TO ANY PERSON OR ENTITY FOR BREACH OF WARRANTY OR FOR BREACH OF ANY OTHER COVENANT, DUTY, OR OBLIGATION ON THE PART OF XERXES. XERXES SHALL HAVE NO LIABILITY OR OBLIGATION TO ANY PERSON OR ENTITY FOR BREACH OF ANY OTHER COVENANT, DUTY, OR OBLIGATION UNDER THIS WARRANTY EXCEPT AS EXPRESSLY SET FORTH HEREIN. IT IS EXPRESSLY AGREED THAT THIS WARRANTY DOES NOT FAIL OF ITS ESSENTIAL PURPOSE. XERXES SHALL HAVE NO LIABILITY FOR COSTS OF INSTALLATION OR REMOVAL OF GOODS, ENVIRONMENTAL CONTAMINATION, FIRES, EXPLOSIONS, OR ANY OTHER CONSEQUENCES ALLEGEDLY ATTRIBUTABLE TO A BREACH OF WARRANTY, OR INCIDENTAL, CONSEQUENTIAL, PUNITIVE OR OTHER DAMAGES OF ANY DESCRIPTION, WHETHER ANY SUCH CLAIM OR DAMAGES BE BASED UPON WARRANTY, CONTRACT, NEGLIGENCE, STRICT LIABILITY OR OTHER TORT, OR OTHERWISE. IN NO EVENT SHALL XERXES' TOTAL LIABILITY HEREUNDER EXCEED THE ORIGINAL PURCHASE PRICE OF THE GOODS WHICH GAVE RISE TO SUCH LIABILITY.

Consumer Notice: This warranty gives you (Owner) specific legal rights. You (Owner) may also have other rights which vary from state to state.

Oxinol™ is a trademark of Atlantic Richfield Company  
Xerxes® is a trademark of Xerxes Corporation  
ASTM® and ASTM INTERNATIONAL® are trademarks of the American Society for Testing and Materials.

**XERXES**®  
a zcl company

Effective: June 1, 2015  
United States

**ZCL | XERXES®**  
making a **lasting** difference®

# Containment Sumps



# Over 200,000 fiberglass storage tanks manufactured and shipped in North America

ZCL | Xerxes is the largest manufacturer of fiberglass underground storage tanks in the world. As customer needs and industry regulations change, ZCL | Xerxes continues to be the market leader in product innovation.

## Containment Sumps

### Think in decades, not years

Today, more and more customers, US states and Canadian provinces recognize the need for a structurally strong, sturdy containment sump that withstands the forces inherent in underground installations. This is why most installers and owners have moved away from the use of polyethylene containment sumps.

Innovation never stops, and neither do we. Our recently redesigned containment sumps are manufactured for the dual purpose of enclosing fittings and equipment – such as piping and pumps – and containing spills or piping leaks should they occur.

ZCL | Xerxes containment sumps and collars provide easy access to fittings in a variety of applications.

## Consider Double-Wall Sumps

New federal regulations that require periodic leak testing of containment sumps provide an exemption for hydrostatically monitored double-wall sumps in most applications.

Installing our double-wall sump can be a cost-effective way to avoid both the expense and ongoing service involved in meeting this testing requirement. In California, and potentially other states and provinces, regulations require all new sumps to be double-walled.



# Why Choose Our Fiberglass Sump?

For decades, ZCL | Xerxes has established itself throughout North America as a leading manufacturer of long-life, corrosion-resistant fiberglass vessels and accessories that offer superior protection for the environment. The internal environment of containment sumps is very corrosive. The use of ethanol, ultra-low sulfur diesel (ULSD) and biodiesel fuels, and the corrosion damage caused by these fuels and resulting vapors is increasing. Our fiberglass containment sumps offer customers a corrosion-resistant, long-term option for the storage of liquids in underground installations.

## A Variety of Sump Options

Whether a customer is installing a new underground system or is retrofitting an existing installation, containment sumps are used on nearly all double-wall tanks today. We supply containment collars and sumps as a package to provide secondary containment around tank fittings, piping, pumps and manways. Customers have the option of either dry interstitial monitoring or hydrostatic monitoring. Most double-wall containment sump installations are equipped with hydrostatic monitoring for the same reasons that customers choose it as a monitoring method for double-wall tanks – continuous monitoring of both walls 24/7. Our containment sumps come in a variety of models, sizes and cover/top options.

MODELS & MONITORING OPTIONS	COVER/TOP OPTIONS	SIZE OPTIONS
<ul style="list-style-type: none"><li>• Round and flat-sided</li><li>• Double-wall sump with hydrostatic monitoring</li><li>• Double-wall sump with dry monitoring</li><li>• Single-wall sump</li></ul>	<ul style="list-style-type: none"><li>• 32-inch watertight cover</li><li>• 38-inch watertight cover</li><li>• 32-inch friction-fit cover</li><li>• Open top option</li></ul>	<ul style="list-style-type: none"><li>• 42-inch diameter</li><li>• 48-inch diameter</li><li>• 36-inch to 72-inch height</li><li>• Available in shallow and deep burial heights</li></ul>

## THE ZCL | XERXES ADVANTAGE

ZCL | Xerxes double-wall underground storage tanks offer customers several significant design and performance differences that make them a superior choice to both steel tanks and other fiberglass tanks.

- Corrosion-Resistant Inside and Out
- 100% Premium Resin and Glass
- Flexible Design and Installation Options
- Maintenance-Free
- TRUCHEK® Continuous Leak Detection
- 30-Year Limited Warranty

### FUEL COMPATIBILITY

Our UL-listed (1316) and ULC-listed (S615) double-wall fiberglass tanks are listed as compatible with 0-100 percent ethanol storage and warranted for the full range of ethanol-blended gasoline. Since the UL listing for steel tanks does not require ethanol compatibility testing, this is another distinct advantage of fiberglass over steel.

### PARABEAM®

To create a double-wall sump that is structurally strong, ZCL | Xerxes uses Parabeam®, our patented 3D glass-reinforcement material, to bond the sump walls. This is the same design concept that has made our double-wall tanks the most widely used underground tanks in North America. By using our unique woven-glass to create the interstitial space, our sumps are built to avoid weaknesses such as structural collapse and false monitoring alarms due to flexing walls.

### CORROSION RESISTANCE

ZCL | Xerxes tanks and sumps are made of fiberglass, which means they are inherently resistant to corrosion. Because they are corrosion-resistant inside and out, you'll have the peace of mind of choosing products that help preserve and protect the environment. You'll also enjoy a lower cost of ownership than with steel tanks, which corrode over time and require maintenance.

### EXTENSIVE THIRD-PARTY QUALITY TESTING

As further evidence of their durability, ZCL | Xerxes double-wall sumps have passed extensive third-party testing to verify that they withstand interstitial pressure levels that other sumps cannot. Therefore, customers can be assured that our containment sumps are superior to other options in the marketplace.

# Multiple Facilities

## Customers Can Rely on Timely Manufacturing and Delivery of Tanks and Accessories.

With six manufacturing facilities – four in the United States and two in Canada – no matter where customers need fiberglass tanks and accessories shipped, a ZCL | Xerxes manufacturing facility is not far away. No other tank producer offers this kind of manufacturing capability in North America. All our facilities are either UL-listed or ULC-listed.

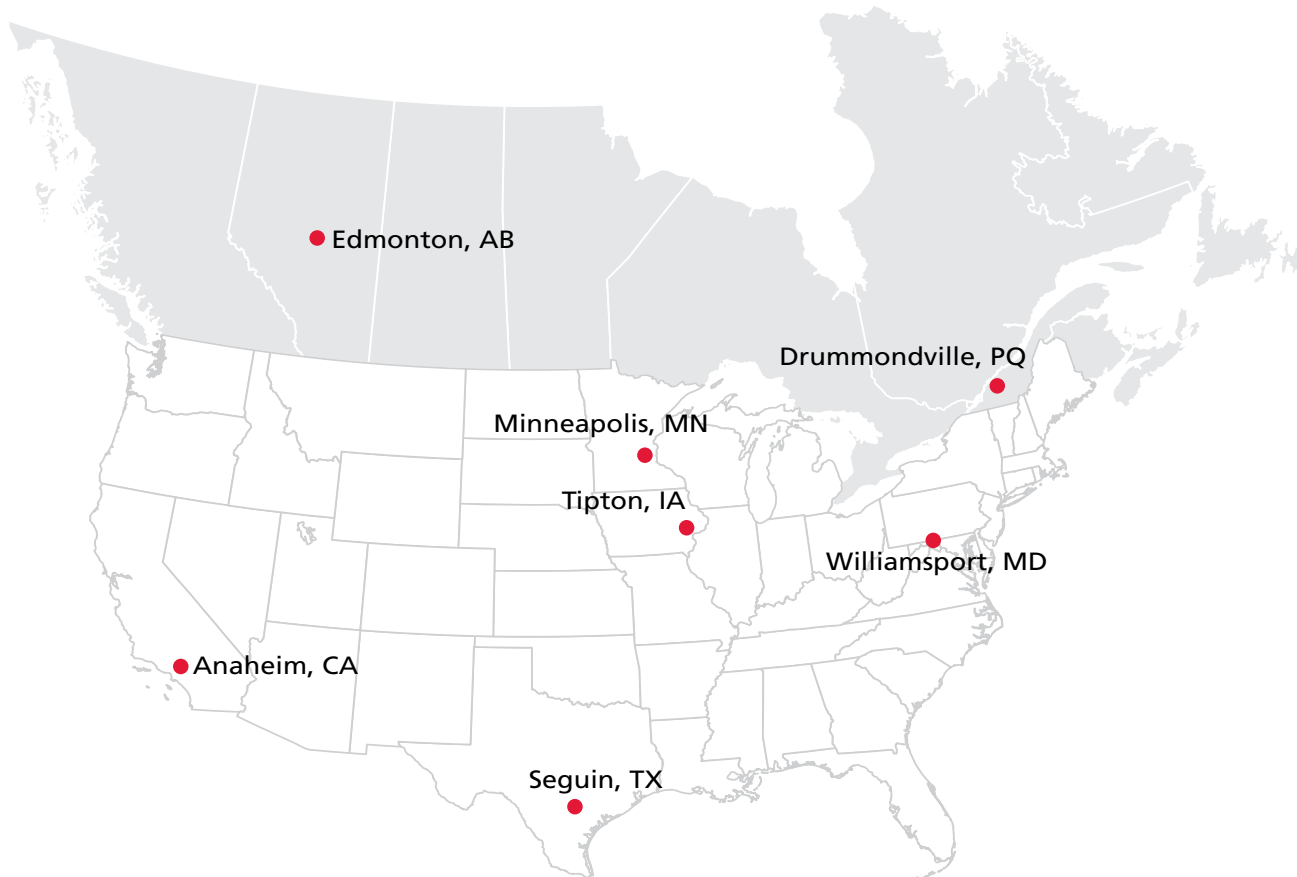

## Contact Us

We're ready to design a sump solution for you. Visit our website, or contact technical support for more information (see contact information below).

**On the Web:**  
[www.zcl.com](http://www.zcl.com)

**Technical Support:**  
800.661.8265  
952.887.1890  
[eng.support@zcl.com](mailto:eng.support@zcl.com)

### Corporate Head Office

**ZCL Composites Inc.**  
1420 Parsons Road SW  
Edmonton, AB T6X 1M5

### US Office

**Xerxes Corporation**  
7901 Xerxes Avenue S  
Minneapolis, MN 55431

### Manufacturing Facilities:

#### Canada

Edmonton, AB  
Drummondville, PQ

#### USA

Anaheim, CA  
Seguin, TX  
Tipton, IA  
Williamsport, MD

## TECHNICAL DATA

2013

### Description

A dark green, opaque, viscous, non-hardening, textured paste with PTFE.

### Type

Slow-drying, soft-setting, non-toxic, brushable, without grit. Cures by solvent evaporation providing a durable, long-lasting seal that can be easily disassembled.

### Typical Uses

Especially designed for ethanol blended gasoline including E10, E20 & E85.

### Substrates

Can be used on brass, copper, stainless steel, aluminum, black pipe, tin, galvanized pipe, ABS plastic, CPVC, nylon, PVC, polyethylene, polypropylene and more.

### Chemical Resistance

Excellent resistance to ethanol blended gasoline, kerosene, petroleum solvents, diesel fuel, propane, butane, LPG, water, cutting oils. NOT oxygen.

### Set Time

None. For immediate service  
Dries to the touch 48-72 hour

### Packaging

Available in 1/4 pint, 1/2 pint and pint cans with brush-top lids.

**For Chemical Emergency, Spill, Leak,  
Fire, Exposure or Accident Call:**

**CHEMTREC - Day or Night. 1-800-424-9300**

**KEEP OUT OF THE REACH OF CHILDREN**

## Product Data Sheet

### Safety

Contains no lead, is non-toxic, not a skin sensitizer, and is non-corrosive.

**Shelf Life:** One year in original containers, when stored at room temperature at or below 80°F (27°C)

**Wt./Gal.:** 11.35 lbs

**Color:** Medium/Green

**Clean Up:** Hand cleaner or alcohol.

### Temperature Range

-100°F to 600°F (-73°C to 316°C)  
Allow to dry thoroughly before exposing to high temperatures. Remains usable in sub-zero weather.

### Pressure Range

Up to 10,000 psi when sealing liquids and up to 3,000 psi with gases. Allow to dry, if possible, before subjecting to pressure.

The information presented is in good faith, but no warranty is given, nor are results guaranteed. Federal Process has no control over physical conditions surrounding application conditions. Federal Process disclaims any liability for untoward results.



FEDERAL PROCESS  
CORPORATION



CLEVELAND, OHIO | 216.464.6440 • 800.846.7325

**www.gasoila.com**

MSDS Sheets Available Online

#DS-ES

## OPW 7150 Overfill Prevention Valves

The CARB-certified OPW 7150 vapor-tight Overfill Prevention Valve is designed to prevent the overfill of underground storage tanks by providing a positive shut-off of product delivery. The shut-off valve is an integral part of the drop tube used for gravity filling. The OPW 7150 allows easy installation (without breaking concrete) and requires no special manholes.

The OPW 7150 is a vapor-tight two-stage shut-off valve. When the liquid level rises to about 95% of tank capacity, the valve mechanism is released, closing automatically with the flow. This reduces the flow rate to approximately 5 gpm through a bypass valve. The operator may then stop the filling process and disconnect and drain the delivery hose. As long as the liquid exceeds the 95% level, the valve will close automatically each time delivery is attempted.

If the delivery is not stopped and the liquid rises to about 98% of tank capacity, the bypass valve closes completely. No additional liquid can flow into the tank until the level drops below a reset point.

NOTE: The 7150 Overfill Prevention Valve can be adjusted to shutoff at any desired tank capacity. Please contact the Authority Having Jurisdiction (AHJ) and review local, state, and national codes to determine the regulatory requirements governing shut-off capacity in your region, as well as take into account other considerations such as extreme tank tilt. In all cases, the upper tube must protrude into the tank at least 6 1/2" to ensure that the valve can shut off flow into the tank completely before the top of the tank is wetted as per EPA requirements.

7150 Instruction Sheet Order Number: H15524PA

### Listings and Certifications



## Materials

- Valve Body:** Cast aluminum
- Float:** Nitrile rubber, closed cell foam
- Valve:** Aluminum
- Seals:** Viton®
- Upper & lower Drop Tube:** Aluminum
- Plastic parts:** Acetal
- Hardware:** Stainless steel

## Features

- ◆ **Simple, Easy and Quick Installation** – no excavation or special manholes required.
- ◆ **Economical** – costs a fraction of expensive, complicated and difficult-to-install valves.
- ◆ **Furnished Complete** – supplied with new upper and lower drop tubes, mounting hardware and thorough instructions for quick job site time.
- ◆ **Completely Automatic Operation** – no prechecks to perform, no resets and no overrides to be broken or abused.
- ◆ **No Pressurization of the Tank** – operates directly from liquid level.
- ◆ **Will Accept a Dipstick for Gauging**

## Advantages of Overfill Prevention Compared to Overfill Warning Systems:

- ◆ **Completely Automatic Operation** – does not rely on the alertness or speed of response of the delivery attendant for certainty of overfill prevention.
- ◆ **Keeps the Top of UST "Dry," per EPA Requirements** – eliminating possible leaks at loose bung fittings and the need for double containment on vent lines.
- ◆ **Does Not Rely on Pressure in the UST to Stop Flow** – allowing faster fill times and reducing spill risk.
- ◆ **Speeds Delivery Operations** – product flows unimpeded into the tank until the hose "kick" that accompanies the valve shut-off provides a clear signal that the liquid has reached the shut-off level.
- ◆ **Simple and Inexpensive Installation** – in both two-point and coaxial fill applications, no additional excavation, manholes or vent piping are required.



Look for this label for authentic OPW EVR Approved products.

**OPW 7150M is EVR Approved for E85**



## Important

In order to prevent product spillage from the Underground Storage Tank (UST), properly maintained delivery equipment and a proper connection at the tight-fill adaptor are essential. Delivery personnel should be managed and trained to inspect delivery elbows and hoses for damaged and missing parts. They should always make certain there is a positive connection between the adaptor and elbow. If delivery equipment is not properly maintained, or the elbow is not securely coupled to the adaptor, a serious spill may result when the OPW 7150 closes, causing a hazard and environmental contamination.

NOTE: The OPW 7150 is designed for use on tight-fill gravity drop applications only. Do not use for pressure fill applications.

- ◆ **Retrofits Directly** – for both new and existing tanks with 4" fill risers.
- ◆ **Quick Drain Feature** – automatically drains hose when head pressure is relieved.
- ◆ **Best Flow Rate in The Industry\***

\* OPW Test Lab results

## Raising The Standard In Overfill Prevention

From the company that brought you the industry standard OPW 6150, OPW raises the standard with the introduction of the **7150 Overfill Prevention Valve** – breakthrough innovation that takes overfill prevention to a whole new level of overfill perfection.

- **Eliminates curing issues due to hot or cold temperatures**
- **Easier, quicker, installation**
- **Higher quality, more reliable installation**
- **Lower costs**
- **Greater protection against fugitive emissions and pressure decay**
- **Fastest flow rate in the industry**

The new 7150 is a two-stage, positive shut-off valve, providing completely automatic operation with no pre-checks to perform, no resets, and no overrides to be broken or abused. The valve closes when the tank level rises to 95% capacity and provides a special bypass valve so the tank can be filled to a maximum capacity of 98%. The 7150 is available for direct-bury and remote applications.



All Vapor-Tight Overfill Valves are CARB EVR Certified



**No Epoxy Sealants Required!**

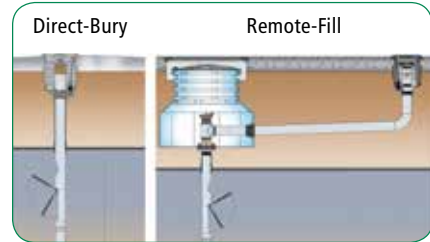

### Replacement Parts

Part #	Description
6150K-0001	Replacement Float Kit
H11931M	Drop Tube Seal
H14840M	Lower Tube Seal
C05117	Lower Tube
D02508	Vapor-Tight Inlet Tube
C03899M	Non-Vapor-Tight Inlet Tube
D02508	Vapor-Tight Inlet Tube (Blue)

## 7150 Ordering Specifications

Product #	Description	Bury Depth		Tank Diameter		Upper Tube Length		Lower Tube Length		Overall Length		Max. Riser Length		Max. Nominal Tank Dia.		Max. Actual Tank Dia.		Weight	
		ft.	m	ft.	m	in.	m	in.	m	in.	m	in.	m	in.	m	in.	m	lbs.	kg
7150-400CB*	Vapor-Tight Overfill Valve	5	1.5	8	2.4	60	1.5	83	2.1	155 <sup>3</sup> / <sub>4</sub>	3.9	53 <sup>1</sup> / <sub>2</sub>	1.4	96	2.4	107	2.7	16	7
7150-410CB*	Vapor-Tight Overfill Valve	10	3.0	10	3.0	120	3.1	102	2.6	234 <sup>3</sup> / <sub>4</sub>	5.9	113 <sup>1</sup> / <sub>2</sub>	2.9	120	3.1	126	3.2	25	11
7150-420CB*	Vapor-Tight Overfill Valve	10	3.0	12	3.6	120	3.1	126	3.2	258 <sup>3</sup> / <sub>4</sub>	6.5	113 <sup>1</sup> / <sub>2</sub>	2.9	144	3.7	150	3.8	26	12
7150-4000	Non Vapor-tight Overfill Valve	5	1.5	8	2.4	60	1.5	83	2.1	155 <sup>3</sup> / <sub>4</sub>	3.9	53 <sup>1</sup> / <sub>2</sub>	1.4	96	2.4	107	2.7	16	7
7150-4010	Non Vapor-tight Overfill Valve	10	3.0	10	3.0	120	3.1	102	2.6	234 <sup>3</sup> / <sub>4</sub>	5.9	113 <sup>1</sup> / <sub>2</sub>	2.9	120	3.1	126	3.2	25	11
7150M-412C	E85 Vapor-tight Overfill Valve	10	3.0	10	3.0	120	3.1	102	2.6	234 <sup>3</sup> / <sub>4</sub>	5.9	113 <sup>1</sup> / <sub>2</sub>	2.9	120	3.1	126	3.2	38	17.3
7150-TOOLCT	7150 Installation Tool																	2.5	1
61JSK-4RMT	Jack Screw Kit For Vapor-Tight Remote Applications																	1.5	0.7
61JSK-4410	Jack Screw Kit For Composite Base Spill Bucketst																	1	0.5
61JSK-44CB	Jack Screw Kit For Cast Iron Base Spill Buckets																	1	0.5
71JSK-4RMT	E85 Jack Screw for Remote-Fill Applications																	1	0.5
71JSK-44MA	E85 Jack Screw for Direct-Fill Applications																	1.5	0.7

61JSK-4410 AND 61JSK-44CB Instruction Sheet Order Number: **H15289M**

\*ULC B100 Compatible

## 7150 Vapor-Tight Remote Fill

The OPW Vapor-Tight Remote Fill is designed for two-point vapor-tight remote-fill applications, where the fill point is not directly over the UST. A CARB approved vapor-tight 7150 overfill valve is installed in the sump through a riser pipe directly over the tank.

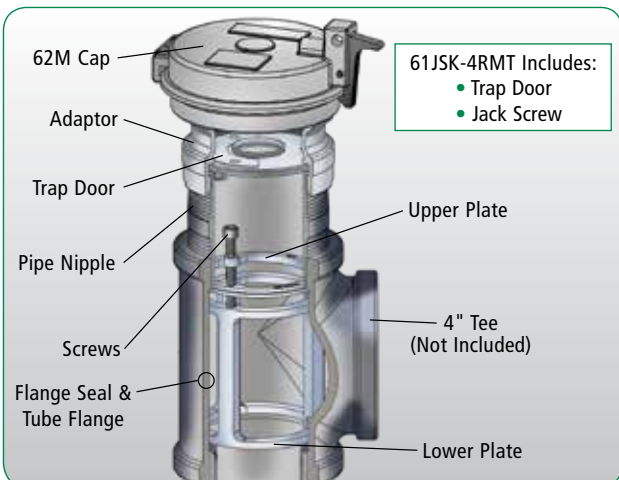

61JSK-4RMT Includes:  
• Trap Door  
• Jack Screw

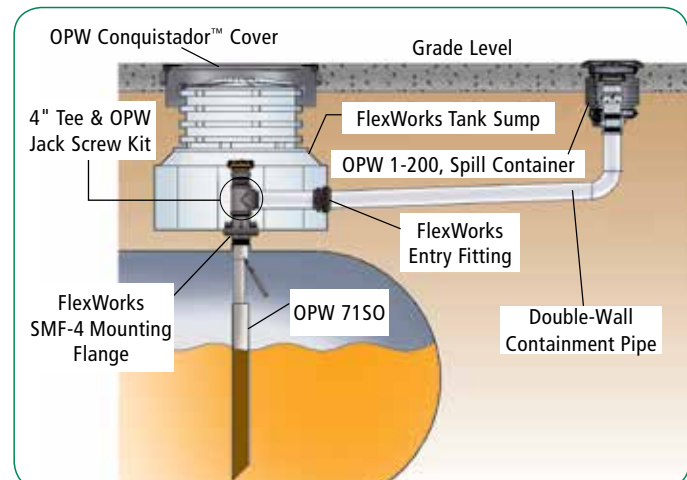



# Franklin Fueling Systems

May 4, 2018

Subject: Franklin Fueling Overfill Prevention Valve (OPV) and Spill Prevention Equipment Fuel Compatibility

To Whom It May Concern,

This letter affirms that the materials used by Franklin Fueling Systems in the construction of the Overfill Prevention Valve (OPV) and Spill Prevention Equipment listed herein, as of the date of this letter, is compatible with the following fuels as defined by ASTM:

### Group 1

- Gasoline (E0 to E10)
- Diesel (B0 to B5)
- Heating Fuels (Kerosene, Fuel Oil)

### Group 2

- Mid-level Ethanol Fuel Blends (E11 to E50)
- Ethanol Fuel Blends (E51 to E83\*)

\*Commercially know as E85

### Group 3

- Biodiesel Blends (B5 to B20) and Biodiesel (B100)

### Group 4

- Aviation Fuels (AvGas, Jet Fuel)

### Overfill Prevention Valves

Model Numbers		Groups
708591901, 708591902, 708592901, 708592902, 708593901, 708593902	Defender Series™ OPVs with standard drop tubes	1
708591921, 708591922, 708592921, 708592922, 708593923, 708593924, 708594901, 708594902	Defender Series™ OPVs, AGB	1, 2, 3, 4
708226901	Defender Series™ Remote fill splice kit	1, 2, 3, 4



# Franklin Fueling Systems

## Spill Containment

Model Numbers		Groups
702xxxxx, 705xxxxx, 715xxxxx	EBW Series Direct Bury Spill Containers	1
705545xxx, 705555xxx, 705556xxx	Defender Series™ Direct Bury Spill Containers	1, 2, 3, 4
DMP36xxxxxx, DMP42xxxxxx	Defender Series™ Multiports	1, 2, 3, 4
SWF-100-SS, SWV-101-SS	Stainless Steel Swivel Adapters	1, 2, 3**, 4
77720102	4" Top Seal Fill Cap	1, 2, 3
30430103, 30430104	4" Vapor Recovery Cap	1, 2, 3

\*\*B100 not determined on this equipment

Please let me know if there are any other questions of concerns regarding Franklin Fueling Overfill Prevention Valve (OPV) and Spill Prevention Equipment Fuel Compatibility.

Regards,

Nicole Keppy  
Franklin Fueling Systems  
Product Manager, Service Station Hardware



## ADVANCED PROTECTION SUBMERSIBLE TURBINE PUMPS

Available as a factory installed option on STPAG and IST biofuel compatible submersible turbine pumps, Advanced Protection defends STPs from accelerated corrosion caused by the acetic byproduct of microbial activity.

### Highlights

- Powder-coated and E-coated finishes protect exterior cast surfaces from accelerated corrosion.
- Stainless steel fasteners, riser, variable length column pipe and coupler protect against corrosion and provide long service life.
- UL and cUL listed.

### Ordering Information

A typical turbine model designation has up to five components to define the pump being supplied as follows:

#### STP XXXXX Y-A-B

##### STP = Basic Model Designation (IST for variable speed models)

**XXXXX = Factory Installed Options** (Model designations may include one or more of the following characters in alphabetical order.)

AP = Advanced protection with coated exterior cast surfaces, stainless steel fasteners and piping, alcohol-gasoline compatible)

F = Floating suction adapter (1½" NPT female adapter)

H = High pressure deadhead output (150 and 200 models only)

K = Intake filter screen (IFS, factory installed to PMA)

M = MagShell™ (flow enhancing, expanded PMA shell)

R = Model R check valve (24 psi relief/22 psi reset for PLLD)\*

W = Model W check valve (16 psi relief/13 psi reset for PPM4000)\*

##### Y = Pump Motor Horsepower Rating

33 = 1/3 hp fixed speed

200 = 2 hp fixed speed

75 = ¾ hp fixed speed

VS2 = 2 hp variable speed\*\*

150 = 1½ hp fixed speed

VS4 = 4 hp variable speed\*\*\*

##### A = Model Length

VL1 = Variable length range #1

VL2 = Variable length range #2

VL3 = Variable length range #3

##### B = Riser Pipe Length

Riser pipe length is expressed as two numeric characters that indicate the total length of the riser in inches. Riser pipes are available from 7" to 60" in 1" increments (additional charge for risers 31" or longer).

Notes:

\*If not otherwise specified, all STP models are supplied with standard model check valve (40 psi relief /35 psi reset for MLD, TS-LS300, and TS-LS500).

\*\*Implied on IST models unless VS4 is specified.

\*\*\* IST models only.

(Advanced Protection STP shown with MLD+ and IFS, sold separately)

## Ordering Information continued

### Advanced Protection Submersible Turbine Pumps

Model	Description	Model Length Range*
ISTAPMVS4-VL1	4 hp AP variable speed with MagShell™	64"-92"
ISTAPMVS4-VL2	4 hp AP variable speed with MagShell™	95"-156"
ISTAPMVS4-VL3	4 hp AP variable speed with MagShell™	127"-218"
ISTAPM-1	2 hp AP variable speed with MagShell™	59"-87"
ISTAPM-2	2 hp AP variable speed with MagShell™	90"-151"
ISTAPM-3	2 hp AP variable speed with MagShell™	122"-213"
STPAPM200-VL1	2 hp AP fixed speed with MagShell™	63"-91"
STPAPM200-VL2	2 hp AP fixed speed with MagShell™	94"-154"
STPAPM200-VL3	2 hp AP fixed speed with MagShell™	126"-217"
STPAPHM200-VL1	2 hp AP high pressure fixed speed with MagShell™	63"-92"
STPAPHM200-VL2	2 hp AP high pressure fixed speed with MagShell™	94"-155"
STPAPHM200-VL3	2 hp AP high pressure fixed speed with MagShell™	126"-218"
STPAP150-VL1	1-1/2 hp AP fixed speed	60"-88"
<b>STPAP150-VL2</b>	<b>1-1/2 hp AP fixed speed</b>	<b>91"-152"</b>
STPAP150-VL3	1-1/2 hp AP fixed speed	123"-214"
STPAPH150-VL1	1-1/2 hp AP high pressure fixed speed	61"-89"
STPAPH150-VL2	1-1/2 hp AP high pressure fixed speed	92"-152"
STPAPH150-VL3	1-1/2 hp AP high pressure fixed speed	124"-215"
STPAP75-VL1	3/4 hp AP fixed speed	57"-86"
STPAP75-VL2	3/4 hp AP fixed speed	88"-149"
STPAP75-VL3	3/4 hp AP fixed speed	120"-212"

#### Notes:

1. Remove "M" from model number for non-MagShell™ pump motor assembly (where applicable).
- 2. STPAP/ISTAP models are listed for compatibility with fuel mixtures containing diesel fuel with up to 20% biodiesel, 100% biodiesel, up to 85% ethanol with gasoline, and 20% MTBE, 20% ETBE or 17% TAME with gasoline.**
3. All models are supplied with a standard check valve unless factory option "R" or "W" is specified.
4. All above ISTAP models can only be powered by a MagVFC™. 4 hp models require three-phase incoming power supply, 2 hp models can be supplied with single- or three-phase incoming power.
5. All above STPAP models require single-phase, 208-230 VAC, 60 Hz incoming power.
6. 4" riser pipe, if supplied locally, must be 4½" OD by 3/16" WT tubing.
7. For riser pipe lengths 31" to 60", adder charge applies.

\*Model length (A) defined as the dimension from the turbine manifold bottom to the pump motor inlet.

### Factory Installed Options

Specified in model number at time of STP order.

Model	Description
F	Floating suction adapter, 1½" NPT female, must be factory installed
K	IFS (intake filter screen) factory assembled to pump motor assembly
R	Model R check valve, factory installed, for Veeder-Root™ PLLD Line Leak
W	Model W check valve, factory installed, for Red Jacket PPM4000 Line Leak

## Ordering Information

### Field Installed Options

Model	Description
5874202800	MagVFC™, 2 hp or 4 hp variable frequency controller, one required per IST
400137908	Syphon check valve (when ordered with STP)
400818921	STP-CBS, single-phase control box with lockout switch, 110 Volt coil
402312921	STP-DHI-SCI, combo DHI with factory wired STP-SCI (when purchased with a 4" STP)*
402312921	STP-DHI-SCI, combo DHI with factory wired STP-SCI (when purchased without a 4" STP)
402313921	STP-DHI-CBS, combo DHI with factory wired STP-CBS
402459931	Model 65 psi check valve (for slave of manifolded STPs with Veeder-Root™ PLLD)
402507930	Secondary syphon kit (when two syphon primes are required for one STP)
5800100215	STP-SCI, single-phase smart controller (when purchased without a 4" STP)
5800100215	STP-SCI, single-phase smart controller (when purchased with a 4" STP)*
5800300100	STP-DHI, dispenser hook isolation for 110 Volt dispenser handle switches, up to eight each

\*When purchasing STP-SCI or STP-DHI-SCI in equal quantities of fixed speed 4" STPs, the STP-SCI or STP-DHI-SCI will be invoiced at special discount pricing.

# FE PETRO®

A Franklin Fueling Systems Brand

franklinfueling.com

3760 Marsh Rd. • Madison, WI 53718, USA

Tel: +1 608 838 8786 • Fax: +1 608 838 6433

Tel: USA & Canada +1 800 225 9787 • Tel: UK +44 (0)1473 243300

Tel: Mex 001 800 738 7610 • Tel: FR +33 (0)1 69 21 41 41 • Tel: CH +86 10 8565 4566



# Magnetostrictive Probes for Alternative Fluids

## Certified performance for inventory control and in-tank leak detection in fuel blends up to 100% alcohol

Veeder-Root offers two types of Magnetostrictive Probes for Alternative Fluids to provide highly accurate, trouble-free in-tank leak detection and inventory control in fluids of up to 100% alcohol. The Magnetostrictive Probe for Alternative Fluids with water detection is ideal for fuel blends with less than 20% alcohol. The Magnetostrictive Probe for Alternative Fluids without water detection has been developed for fluids up to 100% alcohol.

### Series 8463 0.1 GPH Mag Probe for Alternative Fluids

The 0.1 GPH Mag Probe for Alternative Fluids has been third-party tested and certified to perform far better than the U.S. E.P.A. standards for both 0.1 GPH volumetric tank tightness testing and 0.2 GPH automatic tank gauging. (See the summary of leak test performance on back or call us for a copy of the complete test results.)

### 0.1 GPH Mag Probe and CSLD — Leak detection without shutting down your tanks!

CSLD, Continuous Statistical Leak Detection, is an advanced tank testing technology that makes full use of the TLS-300 and TLS-350(R)'s in-tank monitoring capabilities. CSLD eliminates the need for tank shutdown to perform a leak test — no lost business, no lost operating time!

The TLS-300 and TLS-350(R) equipped with CSLD use the 0.1 GPH Mag Probe to continuously monitor fuel height and temperature information to detect idle times in the tank. During each idle time, data collected forms a highly accurate leak detection database. Sophisticated statistical analysis techniques in CSLD constantly evaluate the database to discard invalid data and perform leak tests based on only high-quality information in the current database. In fact, a new leak test is performed every time new data from an idle period is added.

### Series 8463 0.2 GPH Mag Probe for Alternative Fluids

The 0.2 GPH Mag Probe for Alternative Fluids provides the same reliable inventory control features and fluid compatibility as the 0.1 GPH Mag Probe for Alternative Fluids, but offers 0.2 GPH leak detection at a lower cost.

The 0.2 GPH Mag Probe for Alternative Fluids has also been third-party tested and certified to exceed U.S. E.P.A. standards for 0.2 GPH automatic tank gauging. (See the summary of leak test performance on back or call us for a copy of the complete test results.)

### Approved for Aboveground Tank Applications

Veeder-Root Magnetostrictive Probes are approved for use in aboveground storage tanks to monitor fuel inventory. An AST installation Kit (Form Number 312020-984) is required for these applications and is available from Veeder-Root, Customer Service 800-873-3313 or your authorized Veeder-Root distributor.

### Features & Benefits

- Non-corrosive, stainless steel tubing for long-life monitoring in fuels up to 100% alcohol
- Highly accurate Magnetostrictive measurement technology
- Fast accurate leak tests
- 0.1 GPH Mag Probe for Alternative Fluids is third-party certified to exceed U.S. E.P.A. performance standards for 0.1 GPH Volumetric Tank Tightness Testing
- 0.1 GPH Mag Probe for Alternative Fluids is compatible with TLS-300 and TLS-350R with CSLD for continuous statistical leak detection
- 0.2 GPH Mag Probe for Alternative Fluids is third-party certified to exceed U.S. E.P.A. performance standards for 0.2 GPH Automatic Tank Gauging
- 2", 3" and 4" Float Kits available



*Magnetostrictive Probes for Alternative Fluids are available in 0.1 GPH and 0.2 GPH Versions*

## Probe Models

Tank I.D.	Mag Plus Probes for Alternative Fluids with Water Detection Part No*			Mag Plus Probes for Alternative Fluids without Water Detection Part No*		
	0.1 GPH Leak Detection	0.2 GPH Leak Detection	Inventory Only	0.1 GPH Leak Detection	0.2 GPH Leak Detection	Inventory Only
4'	846391-101	846391-201	846391-301	846391-401	846391-501	846391-601
5'	846391-102	846391-202	846391-302	846391-402	846391-502	846391-602
5'4"	846391-103	846391-203	846391-303	846391-403	846391-503	846391-603
6'	846391-104	846391-204	846391-304	846391-404	846391-504	846391-604
7'	846391-105	846391-205	846391-305	846391-405	846391-505	846391-605
7'6"	846391-106	846391-206	846391-306	846391-406	846391-506	846391-606
8'	846391-107	846391-207	846391-307	846391-407	846391-507	846391-607
9'	846391-108	846391-208	846391-308	846391-408	846391-508	846391-608
9'6"	846391-117	846391-217	846391-317	846391-417	846391-517	846391-617
10'	846391-109	846391-209	846391-309	846391-409	846391-509	846391-609
10'6"	846391-110	846391-210	846391-310	846391-410	846391-510	846391-610
11'	846391-111	846391-211	846391-311	846391-411	846391-511	846391-611
12'	846391-112	846391-212	846391-312	846391-412	846391-512	846391-612
2.0M	846391-113	846391-213	846391-313	846391-413	846391-513	846391-613
2.5M	846391-114	846391-214	846391-314	846391-414	846391-514	846391-614
2.67M	846391-116	846391-216	846391-316	846391-416	846391-516	846391-616
3.0M	846391-115	846391-215	846391-315	846391-415	846391-515	846391-615
Custom Length	846391-199	846391-299	846391-399	846391-499	846391-599	846391-699

\*Float kits must be ordered separately from probes, water floats not recommended for fuel blends with >20% alcohol

## Floats Match Table

Product	Probe	Functions	Float Kit
Gasoline (<=20% Alcohol)	Mag Plus Probe for Alternative Fluids with Water Detection P/N 846391-1xx or -2xx	Inventory: Yes Leak Detection: Yes Water detection: Yes	Gasoline Float Kit P/N 846400-xy0* (*see note for definition of xy below)
	Inventory Only Mag Plus Probe for Alternative Fluids with Water Detection P/N 846391-3xx	Inventory: Yes Leak Detection: No Water detection: Yes	
Alcohol / Ethanol (<=100% Alcohol, including E85) Methanol (<=100% Alcohol) ETBE (<=100% Ether) MTBE (<=100% Ether) Used Oil	Mag Plus Probe for Alternative Fluids without Water Detection P/N 846391-4xx or -5xx	Inventory: Yes Leak Detection: Yes Water Detection: No	Alternative Fluids Float Kit P/N 846400-xy4*  *Notes: x=0 -> 4" floats x=1 -> 2" floats x=3 -> 3" floats  y=0 -> 5' cable y=1 -> 10' cable y=2 -> 20' cable
	Mag Plus Probe for Alternative Fluids without Water Detection P/N 846391-6xx	Inventory: Yes Leak Detection: No Water Detection: No	
Fuel Oil #4 & #6 Fuel Oil #4 & #6 Ethylene Glycol Propylene Glycol Windshield Washer Fluid	Mag Plus Probe for Alternative Fluids without Water Detection P/N 846391-6xx	Inventory: Yes Leak Detection: No Water Detection: No	

## Leak Test Performance (Third Party Certified for all TLS-3xx Consoles\*)

PROBE	TEST TYPE	P(D)	P(FA)	TEST TIME
0.1 GPH Mag Probe	0.1 GPH	99%	1%	3 Hours
0.1 GPH Mag Probe	0.2 GPH	99%	<.1%	2 Hours
0.1 GPH Mag Probe w/CSLD	0.2 GPH	99%	<.1%	Continuous
0.2 GPH Mag 2	0.2 GPH	99%	<.1%	2 Hours

Veeder-Root reserves the right to change product specifications without advance notice. Please ensure that you are using the latest version of product literature.



© 2007 Veeder-Root Company • 125 Powder Forest Drive • Simsbury, CT 06070 • USA  
Telephone: 860-651-2700 • Fax : 860-651-2719 • www.veeder.com

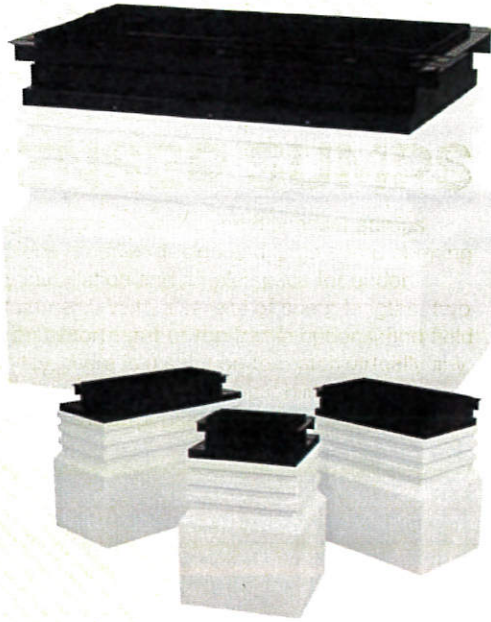

## LARGE MOUTH POLYETHYLENE DISPENSER SUMPS

APT™ brand large mouth polyethylene dispenser sumps feature a two-piece modular design and large sump opening to provide easy installation and ample space for under dispenser containment. With a variety of sump lengths, two depth options, an assortment of top frame options, and field height adjustability, there is a solution to match virtually any application and provide complete compatibility with the industry's most popular dispenser models.

### HIGHLIGHTS

- The ribbed riser can be cut down in 3" increments in the field to adjust sump height and achieve proper pipe slopes with respect to grade.
- Available in medium (28") and deep(43") burial depths to properly maintain slope.
- 22" wide by 24", 36", or 48" long opening on base gives plenty of room for boot, fitting, and monitor installation.
- The sump base widens to a spacious 26" where entry boots and pipe connections are made.
- Corrosion-resistant powder coated steel top frames provide durability and extended service life.
- Stabilizer bar kits (SBKs) mount into welded strut channels for shear valve mounting (one SBK is required for each shear valve and must be purchased separately).

### SPECIFICATIONS

#### Approvals/Certifications

- ULc listed.
- Florida EQ-423 approved.

#### Components

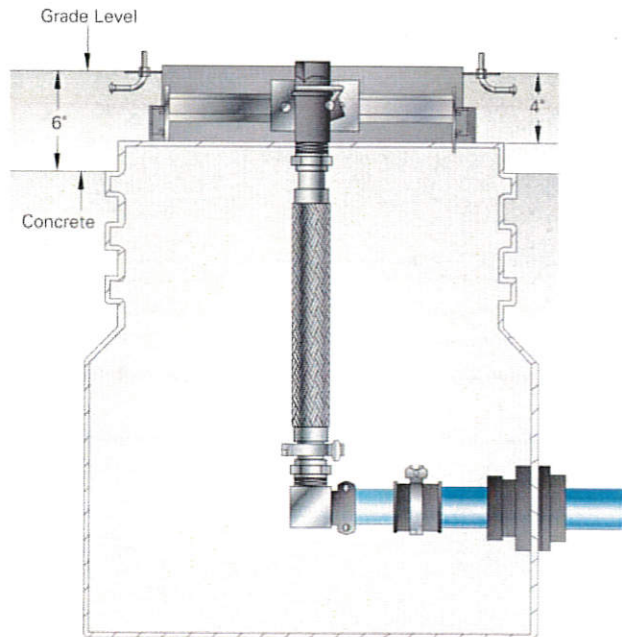



April 25th, 2019

Mark Bennett  
Director of Field Services  
Stenstrom  
2422 Center Street P.O. Box 5946  
Rockford, Illinois 61125  
815-398-6250  
[markb@rstenstrom.com](mailto:markb@rstenstrom.com)

Dear Mr. Bennett,

Franklin Fueling Systems certifies that our poly and fiberglass containment range are certified to meet the ASTM D5798 standard which has a provision for compatibility with high blend ethanol within the UL 2447 listing.

*Per ASTM D5798 within the scope section 1.3 This specification formerly covered Fuel Ethanol (Ed70-Ed85) for Automotive Spark-Ignition Engines, also known commercially as E85. The nomenclature "fuel ethanol" has been changed to "ethanol fuel blends" to distinguish this product from denatured fuel ethanol Specification D4806. To facilitate blending of ethanol fuel blends that meet seasonal vapor pressure requirements, a new lower minimum ethanol content has been established.*

For more information on ASTM D5798 follow the link below:

<https://www.astm.org/Standards/D5798.htm>

Sincerely,

A handwritten signature in black ink, appearing to read 'All Busch'.

Allan Busch  
Senior Product Manager – Piping & Containment Systems  
Franklin Fueling Systems

**SPECIFICATIONS CONTINUED**

**Approvals/Certifications**

- ULC Listed (grade level CI-GKT versions only).
- CARB approved (grade level only).
- Exceeds H20 and HS20 load standards (maximum axle load requiring support for the 32,000 or 16,000 pounds for each set of dual tire wheels).

**ORDERING INFORMATION**

**Ordering Guide**

Complete spill container part numbers have a specific order and are created using the following guidelines:

**705 XXXY A B C**

**XXX = Containment Options**

- 545 = Grade level single wall
- 555 = Grade level double wall
- 556 = Below grade double wall

**Y = Interstitial Monitoring Options**

- 0 = No sensor
- 1 = Visual monitor (float gauge)
- 2 = Electronic sensor monitor

**A = Base Thread Options**

- 0 = NPSM
- 1 = NPT
- 2 = BSPT

**B = Drain Options**

- 1 = With drain
- 2 = Without drain

**C = Lid/Cover**

- BLK = Black fiberglass 18" manway cover (below grade only)
- CI-GKT = Black epoxy-coated cast iron gasketed lid (grade level only)
- CI-GRN = Green epoxy-coated cast iron gasketed lid (grade level only)
- CI-ORG = Orange epoxy-coated cast iron gasketed lid (grade level only)
- CI-RED = Red epoxy-coated cast iron gasketed lid (grade level only)
- CI-WHT = White epoxy-coated cast iron gasketed lid (grade level only)
- CI-YEL = Yellow epoxy-coated cast iron gasketed lid (grade level only)

Example: **705555111CI-GKT** = Defender Series® grade level double wall spill container with visual monitor, with NPT base thread, with drain and with black cast iron gasketed lid.

Example: **705556211BLK** = Defender Series® below grade double wall spill container with electronic sensor monitor, with NPT base thread, with drain and with black fiberglass manway cover (manway included).

**Defender Series® Spill Containers Common Configurations**

Model	Description
705545001CI-GKT	Defender Series® grade level, single wall, NPSM thread, with drain, with black epoxy-coated cast iron gasketed lid
705545002CI-GKT	Defender Series® grade level, single wall, NPSM thread, without drain, with black epoxy-coated cast iron gasketed lid
705545011CI-GKT	Defender Series® grade level, single wall, NPT thread, with drain, with black epoxy-coated cast iron gasketed lid
705545012CI-GKT	Defender Series® grade level, single wall, NPT thread, without drain, with black epoxy-coated cast iron gasketed lid
705545021CI-GKT	Defender Series® grade level, single wall, BSPT thread, with drain, with black epoxy-coated cast iron gasketed lid
705545022CI-GKT	Defender Series® grade level, single wall, BSPT thread, without drain, with black epoxy-coated cast iron gasketed lid
705555101CI-GKT	Defender Series® grade level, double wall, NPSM thread, with drain, with visual monitor, with black epoxy-coated cast iron gasketed lid
705555102CI-GKT	Defender Series® grade level, double wall, NPSM thread, without drain, with visual monitor, with black epoxy-coated cast iron gasketed lid
705555111CI-GKT	Defender Series® grade level, double wall, NPT thread, with drain, with visual monitor, with black epoxy-coated cast iron gasketed lid
705555112CI-GKT	Defender Series® grade level, double wall, NPT thread, without drain, with visual monitor, with black epoxy-coated cast iron gasketed lid
705555211CI-GKT	Defender Series® grade level, double wall, NPT thread, with drain, with electronic sensor monitor, with black epoxy-coated cast iron gasketed lid
705555212CI-GKT	Defender Series® grade level, NPT thread, without drain, with electronic sensor monitor, with black epoxy-coated cast iron gasketed lid
705556111BLK	Defender Series® below grade, double wall, NPT thread, with drain, with visual monitor, with black fiberglass manway cover (18" manway included)
705556112BLK	Defender Series® below grade, double wall, NPT thread, no drain, with visual monitor, with black fiberglass manway cover (18" manway included)
705556211BLK	Defender Series® below grade, double wall, NPT thread, with drain, with electronic sensor monitor, with black fiberglass manway cover (18" manway included)
705556212BLK	Defender Series® below grade, double wall, NPT thread, no drain, with electronic sensor monitor, with black fiberglass manway cover (18" manway included)
705559901*	Defender Series® grade level cutaway display, double wall, with drain, with visual monitor

\*For display and demonstration purposes only. Six to eight week lead time.

**Defender Series® Spill Container Installation Tools**

Model	Description
T-7001	T-handle wrench
T-7106	Double-ended installation tool
T-7107	Double wall vacuum test kit (for double wall models only)

# Dualoy® 3000/LCX Product Data

---

## Applications

Rigid fiberglass coaxial fuel handling systems requiring Underwriters Laboratories Listing for integral primary and containment piping conveying the following fuels:

- Motor Vehicle (MV)
- Aviation and Marine A&M)
- High Blend (HB)
- Bio-Diesel
- Concentrated (CT)
- Diesel Exhaust Fluid

---

## Description

Dualoy 3000/LCX rigid fiberglass coaxial piping is a cost-effective solution for contained piping systems. LCX is used for product delivery lines in underground fuel handling systems to convey fuel from the tank to the dispensers. Dualoy 3000/LCX pipe is UL Listed for use with motor vehicle (MV), high blend (HB), concentrated (CT) and aviation and marine (A&M) fuels. Based on currently known tests, **NOV Fiber Glass Systems found this product to be suitable for conveying all blends of biodiesel and ethanol type fuels and the conveyance of DEF.**

The LCX pipe is manufactured as an integral unit. The primary is made of chemically inert, non-permeable, fiberglass reinforced epoxy resin which is inherently resistant to deterioration due to water and microbial attack. This layer is covered with a porous layer to provide the small volume interstitial space, which facilitates rapid leak detection. Then, the containment layer, comprised of the same material as the primary, is wound over the primary and porous layers.

The containment system is installed with custom designed clamshell containment fittings. Both the primary and containment systems are bonded for long-term, reliable performance.

- Dualoy 3000/LCX containment fittings are typically bolted in place while the adhesive cures.
- Dualoy 3000/LCX reduces installation and inspection time dramatically, retaining system integrity.
- Dualoy 3000/LCX double wall design significantly improves impact resistance over single wall pipe.
- Dualoy 3000/LCX systems provide true double wall design which permits rapid communication through the interstice.

---

## Listings and Approvals

The rigid fiberglass piping used in Dualoy 3000/LCX is Listed in the United States with Underwriters Laboratories for nonmetallic underground piping for MV, HB, CT and A&M fuels under File No. MH9162. Dualoy 3000/LCX pipe and fittings are also Listed with Underwriters Laboratories of Canada for Petroleum Products and Oxygenated Fuels (File CMH715). Underwriters Laboratories has also approved Dualoy 3000/L and Dualoy 3000/LCX for use with MTBE fluids.

---

## Performance

Primary operating pressures to 200 psig (13.8 bar)

Continuous operating temperature to 150°F (66°C)

Containment system pressures to 50 psig (3.45 bar)

Individual system components may not have the same ratings as the pipe. Refer to the detailed product information for the specific components to determine the pressure rating for the system as a whole.

---

## Composition

**Primary pipe:** Filament-wound fiberglass reinforced epoxy pipe with integral epoxy liner. When classified in accordance with ASTM D2310 and ASTM D2996, the pipe meets the following cell limits: RTRP 11CF1-5420.

**Pipe containment:** Filament-wound fiberglass reinforced epoxy pipe.

**Interstitial space:** Dry, graded glass beads secured in place with adhesive backed tape.

**Fittings:** Compression molded or filament-wound fiberglass reinforced epoxy primary fittings. Containment fittings are molded.

**Adhesive:** PSX™ •20 or PSX™ •34 ambient-cure, two-part epoxy for all services (including alcohols and MTBE).

## Joining System Primary:

Bell and spigot taper/taper adhesive-bonded joint

### Containment:

Adhesive-bonded clamshell fittings. Parts are compression molded for exact fit and match. Material is identical to primary fittings and is UL Listed for all services, including use in MTBE fluids.

## Pipe Lengths

Standard 20 ft. (6.1 m) random lengths 17 to 21 ft. (5.2 to 6.4 m) and 30 ft. (9.1 m) random lengths 27 to 32 ft. (8.2 to 9.7 m)

Other lengths up to 42 ft. (12.8 m) available upon request.

## Fittings

Primary	Adapters: bell x NPT male <sup>(1)</sup> Adapters: bell x NPT female <sup>(2)</sup> Adapters: spigot x NPT female <sup>(2)</sup> Adapters: spigot x NPT male <sup>(2)</sup> 45° elbows <sup>(1)</sup> 90° elbows <sup>(1)</sup> End caps <sup>(1)</sup> Flange rings <sup>(1)</sup>	Flange stub ends <sup>(1)</sup> Isolation bushings <sup>(1)</sup> Nipples <sup>(2)</sup> Reducer bushings <sup>(1)</sup> Repair couplings <sup>(1)</sup> Sleeve couplings <sup>(2)</sup> Tees <sup>(1)</sup> Dispenser pan penetration fittings <sup>(1)</sup>
Containment	45° elbows <sup>(1)</sup> 90° elbows <sup>(1)</sup> Termination sleeves <sup>(1), (3)</sup>	Couplings <sup>(1)</sup> Tees <sup>(1)</sup>

<sup>(1)</sup> Molded fitting

<sup>(2)</sup> Filament-wound fitting

<sup>(3)</sup> 2" (50 mm) available with or without test valve. 3" and 4" (80 and 100 mm) available only with test valve

## Typical Pipe Dimensions and Weights

Pipe Size		Primary Pipe ID		Primary Pipe OD <sup>(1)</sup>		Primary Wall Thickness		Containment OD		Capacity		Weight	
in	mm	in	mm	in	mm	in	mm	in	mm	gal/ft	l/m	lb/ft	kg/m
2	50	2.21	56	2.37	60	0.080	2.03	2.59	66	0.20	0.76	0.90	1.34
3	80	3.32	84	3.50	89	0.085	2.16	3.70	94	0.45	1.70	1.30	1.93
4	100	4.33	110	4.50	114	0.087	2.21	4.70	119	0.77	2.92	1.74	2.59

<sup>(1)</sup> Typical outside diameters of 2"-4" (50 -100 mm) pipe are within API, ASTM and ANSI fiberglass and steel pipe dimensions.

## Typical Primary Pipe Performance

Pipe Size		Pressure Rating <sup>(1)</sup>		Ultimate Internal Pressure <sup>(1)</sup>		Ultimate Collapse Pressure <sup>(2)</sup>	
in	mm	psig	MPa	psig	MPa	psig	MPa
2	50	200	2.07	1500	10.3	153	1.05
3	80	200	1.38	1000	6.9	90	0.62
4	100	175	1.21	750	5.2	39	0.27

<sup>(1)</sup> At 80°F (27°C)

<sup>(2)</sup> At 80°F (27°C) For continuous service do not exceed 75% of these values.

## Fittings Pressure Performance

Pipe Size		Primary All Fittings		Containment Clamshell Fittings	
in	mm	psig	MPa	psig	kPa
2	50	200	1.38	50 <sup>(1)</sup>	345
3	80	125	0.86	50 <sup>(1)</sup>	345
4	100	100	0.69	20	138

<sup>(1)</sup> With reinforcing rings

For dimensions of primary fittings, consult Dualoy 3000/L Fittings Dimensions document. Pressure ratings of fittings without UL Listing are available on request.

Dualoy 3000/LCX piping systems are designed to function at temperatures ranging from -40 to 150°F (-40 to 66°C) at service pressures between -1 and 13.8 bar. Dualoy 3000/LCX pipe conforms to ASTM D2310, D2517 and D2996.

<b>Typical Physical Properties of Primary Pipe</b>			
Pipe Property	Units	Value	ASTM
Thermal conductivity	Btu-in/(h•ft <sup>2</sup> •°F)	1.7	C177
	W/m•°C	7.6	
Linear thermal expansion	10 <sup>-6</sup> in/in/°F	8.5	D696
	10 <sup>-6</sup> cm/cm/°C	15.3	
Friction factor	Hazen-Williams	150.0	—
Absolute roughness	10 <sup>-6</sup> ft	15.0	—
	10 <sup>-6</sup> m	4.6	
Specific gravity	—	1.81	D792
Barcol Hardness	Impressor 934-1	65.0	D2583

<b>Typical Mechanical Properties of Primary Pipe</b>			
Pipe Property <sup>(1)</sup>	Units	Value <sup>(1)</sup>	ASTM
Tensile strength Longitudinal	10 <sup>3</sup> psi MPa	35.0	D2105
		241.0	
Circumferential	10 <sup>3</sup> psi MPa	70.0	D1599
		483.0	
Tensile modulus Longitudinal	10 <sup>6</sup> psi GPa	2.5	D2105
		17.2	
Circumferential	10 <sup>6</sup> psi GPa	3.8	FGSTM
		26.2	
Compressive strength Longitudinal	10 <sup>3</sup> psi MPa	24.5	FGSTM
		168.9	
Compressive modulus Longitudinal	10 <sup>6</sup> psi GPa	2.6	FGSTM
		17.8	
Cyclic	10 <sup>3</sup> psi MPa	8.0	D2992(A)
		55.0	
Poisson's Ratio <sup>(2)</sup>	—	0.16	FGSTM
		0.17	FGSTM

<sup>(1)</sup> Based on structural wall thickness.

<sup>(2)</sup> The first subscript denotes the direction of applied stress and the second that of measured contraction  
 x denotes longitudinal direction.  
 y denotes circumferential direction.

<b>Bending Radius</b>						
Pipe Size		Minimum Bending Radius <sup>(1)</sup>		Maximum Deflection per 20 ft Joint	Minimum Length Required for 10° Change	
in	mm	ft	m	deg	ft	m
2	50	75	23	15	13	4
3	80	100	38	9	22	7
4	100	150	46	7.5	27	8

<sup>(1)</sup> At rated pressure. Sharper bends may create excessive stress concentrations. Do not bend pipe until adhesive has cured.

National Oilwell Varco has produced this brochure for general information only, and it is not intended for design purposes. Although every effort has been made to maintain the accuracy and reliability of its contents, National Oilwell Varco in no way assumes responsibility for liability for any loss, damage or injury resulting from the use of information and data herein nor is any warranty expressed or implied. Always cross-reference the bulletin date with the most current version listed at the web site noted in this literature.

*North America*

17115 San Pedro Ave. Suite 200  
San Antonio, Texas 78232 USA  
Phone: 210 477 7500

*South America*

Avenida Fernando Simoes  
Recife, Brazil 51020-390  
Phone: 55 31 3501 0023

*Europe*

P.O. Box 6, 4190 CA  
Geldermalsen, The Netherlands  
Phone: 31 345 587 587

*Asia Pacific*

No. 7A, Tuas Avenue 3  
Jurong, Singapore 639407  
Phone: 65 6861 6118

*Middle East*

P.O. Box 17324  
Dubai, UAE  
Phone: 971 4881 3566



**Veeder-Root**  
125 Powder Forest Drive  
P. O. Box 2003  
Simsbury, CT 06070-7684  
USA  
Phone: (860) 651-2700  
Fax: (869) 651-2719

January 13, 2011

**Concerned Regulatory Agency**

Re: Veeder-Root Compatibility with E85

To whom it may concern:

Veeder-Root TLS branded automatic tank gauging products have UL listings for product safety. The wetted component materials used with the below listed products are deemed by Veeder-Root to be compatible with ethanol 85 applications.

<u>VR Part Number</u>	<u>Description</u>
848480-003	Pressurized Line Leak Detector
846391-4XX, 5XX, 6XX	Mag Plus Probes for Alternative Fluids without water detection
846400-004,304,104	Mag Float Kit ( 5" cable) for Alternative Fluids 4", 3" & 2" floats
846400-014,314,114	Mag Float Kit (10" cable) for Alternative Fluids 4", 3" & 2" floats
846400-024,324,124	Mag Float Kit (20" cable) for Alternative Fluids 4", 3" & 2" floats
794380-323	Position Sensitive Pan/Sump Sensor
794380-344	MicroSensor
794380-345	Interstitial Solid State Sensor for Fiberglass Tanks
794380-430	Interstitial Sensor for Steel Tanks

The following sensor is exposed to Brine and is not of concern in an E85 application.

794380-301                      Hydrostatic Sensor

Please contact Veeder-Root Technical Support at 1-800-323-1799 with further questions.

Regards,

Bob Moss  
VP Engineering

# Sensor Application Matrix

Sensor Description	Form #	Page #	Where Used							Category					Fuel Compatibility													
			Dispenser Pan	Spill Containment	STP Sump	Convault Tank	Annular Space	Monitoring Well	Oil/Water Separator tank	Discriminating	Non-Discriminating	Position Sensitive	Level Sensing	Static Testing	Hydrostatic	100% Gasoline	Diesel	Kerosene	Jet Fuel	Aviation Gas	E-15	E-85	E-100	Bio-Diesel 20	Bio-Diesel 100	Renewable (Green) Diesel	Diesel Exhaust Fuel (DEF)	Waste Oil
DPS Standard Dispenser Pan	794380-322	2	X	X					X						X	X	X	X	X	X	X <sup>1</sup>	X		X		X	X	
CSS Standard Containment Sump	794380-352	3		X	X				X						X	X	X	X	X	X	X <sup>1</sup>	X		X		X	X	
DPO Optical Dispenser Pan	794380-320	4	X	X					X						X	X	X	X	X	X	X <sup>1</sup>	X		X		X	X	
CSO Optical Containment Sump	794380-350	5		X	X				X						X	X	X	X	X	X	X <sup>1</sup>	X		X		X	X	
MSS Mag Sump Sensor	857080-XXX	6	X	X	X				X		X	X	X		X	X	X	X	X	X	X	X	X	X	X	X	X	
SSDP Solid-State Dispenser Pan	794380-321	7	X	X						X					X	X	X	X	X	X			X	X	X		X	X
SSCS Solid-State Containment Sump	794380-351	8		X	X					X					X	X	X	X	X	X			X	X	X		X	X
Piping Sump	794380-208	9	X	X	X					X					X	X	X	X	X	X			X		X		X	X
Non-Discriminating Standalone Dispenser Pan	847990-001	10	X	X	X					X					X	X	X	X	X	X			X		X		X	X
Position-Sensitive	794380-323	11	X	X	X					X	X				X	X	X	X	X	X	X	X	X	X	X	X	X	X
Interstitial for Fiberglass Tanks, Discriminating	794380-343	12					X		X						X	X	X	X	X	X			X	X	X	X	X	X
Interstitial for Fiberglass Tanks	794390-409	13					X		X						X	X	X	X	X	X			X		X			
Interstitial for Fiberglass Tanks, High Alcohol	794380-345	14					X		X						X	X	X	X	X	X	X	X	X	X	X	X	X	X
Interstitial for Steel Tanks	794390-4X0	15			X	X			X						X	X	X	X	X	X			X		X		X	X
Interstitial for Steel Tanks, Position Sensitive <sup>2</sup>	794380-333	16		X			X		X	X					X	X	X	X	X	X	X	X	X	X	X		X	X
Interstitial for Steel Tanks, High Alcohol	794380-430	17					X		X						X	X	X	X	X	X	X	X	X	X	X		X	X
Interstitial for Steel Tanks, High Alcohol, small footprint	794380-344	18		X			X		X						X	X	X	X	X	X	X	X	X	X	X	X	X	X
Hydrostatic Reservoir (Dual Point)	794380-303	19					X							X	X	X	X	X	X	X	X <sup>1</sup>	X <sup>1</sup>	X		X		X	X
Single-Point Hydrostatic Sensor	794380-301	20					X							X	X	X	X	X	X	X	X <sup>1</sup>	X <sup>1</sup>	X		X			
Single-Point Mini-Hydrostatic Reservoir (High Alcohol)	794380-304	21					X							X	X	X	X	X	X	X	X	X	X	X	X		X	X
Vapor	794390-700	22					X							X			X	X	X									
Groundwater	794380-62X	23					X							X	X	X	X	X	X				X		X		X	X
Oil / Water Separator	794690-XXX	24					X							X	X	X	X	X	X				X				X	X

<sup>1</sup>Single use only if sensor was exposed to E85 or E100 (Test per Sensor Operability Guide [P/N 577013-814] in E-10 or less)

<sup>2</sup>Small Containment Areas (i.e. Spill Buckets)



# ELECTRONIC PRESSURIZED LINE LEAK DETECTION SYSTEM



## Patented measurement technology

The Veeder-Root Electronic Pressurized Line Leak Detection system can be used in a variety of pressurized line applications. Our patented technology performs leak test at full pump pressure for 0.1 gph precision and a pressure decay test to meet the US EPA's continuous 3.0 gph gross test requirement. When partnered with our TLS-450PLUS Automatic Tank Gauge, large volume customers can now monitor lines that exceed 1100 gallons.





Part Number	Description	Supported Console
859080-001	Digital Pressurized Line Leak Detector (DPLLD) without Swiftcheck Valve	TLS-450PLUS
859080-002	Digital Pressurized Line Leak Detector (DPLLD) with Swiftcheck Valve	TLS-450PLUS
332812-001	16 Input Universal Sensor Module	TLS-450PLUS
332813-001	5 Input and Output Interface Module (STP Control)	TLS-450PLUS

## Key Features

- Proven pressure transducer technology
- No restriction of fuel flow
- Utilizes Swift Check Valve on early generation Red Jacket Submersible Pumps
- Test lines at full pressure for quick and accurate result
- Standard 3.0 gph, Optional 0.2 and 0.1 gph testing
- Not impacted by thermal contraction of fuel
- Installs without breaking piping or adding a new sump
- Supports a wide-range of pump and pipe types
- Several options based on TLS system
- Pressure Sensor constructed with Stainless Steel to meet the challenges of a highly corrosive environment

## Specifications



- Leaded Gasoline
- 5% Methanol
- Up to 100% Ethanol
- 15% MTBE
- Diesel
- Biodiesel (Up to B100)
- Kerosene
- Jet Fuel
- Aviation Gasoline

<b>Line Flow Rate</b>	120 GPM Max w/ Swiftcheck Valve
<b>Operating Range</b>	0 – 70 PSI
<b>Proof Pressure</b>	200 PSI
<b>Maximum Vertical Pipeline Height Above Transducer</b>	11 Feet
<b>Minimum Pump Output Pressure</b>	23 PSI

## Documents

- ↓ [Line Leak Application Guide \(577013-465\)](#)
- ↓ [Exterior Dimensions \ Digital PLLD Sensor \(333526-001\)](#)
- ↓ [PLLD & WPLLD Troubleshooting Manual \(577013-344\)](#)
- ↓ [PLLD Site Prep and Installation Manual \(576013-902\)](#)
- ↓ [WPLLD Site Prep and Installation Manual \(576013-923\)](#)



## TLS-450PLUS Automatic Tank Gauge

The TLS-450PLUS automatic tank gauge provides the most comprehensive fuel site data for advanced fuel asset management.

[Learn More >](#)





[Learn More >](#)

## REQUEST FOR QUOTE

**First name\***

---

**Last name\***

---

**Company name**

---

**Email\***

---

**Phone number**

---

**Country\***

Please Select

---

**Product Interest**

- |   |  |
|---|--|
| <input type="checkbox"/> Automatic Tank Gauges                  | <input type="checkbox"/> Tank Gauge Sensors or Probes  |
| <input type="checkbox"/> Submersible Turbine Pumps              | <input type="checkbox"/> DEF Submersible Turbine Pumps |
| <input type="checkbox"/> Electronic Meter Registers             | <input type="checkbox"/> Mechanical Meter Registers    |
| <input type="checkbox"/> Vapor Recovery / ISD / Carbon Canister |  |



---

**SUBMIT**

Copyright © The Veeder-Root Company.  
All rights reserved. Unauthorized duplication prohibited.

125 Powder Forest Drive PO Box 2003  
Simsbury, CT 06070

1.888.561.7942

[Automatic Tank Gauges  
\(ATG\)](#)

[Meter Registers](#)

[Red Jacket Submersible  
Pumping Systems \(STP\)](#)

[Careers](#)

[Technical Support](#)

[Privacy](#)   [Terms](#)   [Extranet](#)

## XFLO™ FUEL METER



### Xflo™ Fuel Meter

Save fuel, save time, save money.

Without accurately-calibrated dispensers, you could be unintentionally giving away fuel every time customers fill their tanks. The new Wayne Xflo™ Meter can make this a thing of the past. With fewer moving parts and additional calibration points, the Xflo Meter sets the standard in metering accuracy. It's not only accurate, it's also 20-30% faster than traditional piston meters. And faster, more accurate transactions mean more profit to your bottom line.

**Wayne**  
FUELING SYSTEMS

# Xflo™ Fuel Meter

Save fuel, save time, save money.

## So accurate, you may never have to calibrate it again

With the Xflo Meter, expect more accurate metering and less frequent calibration. In both lab and field tests, the Xflo Meter demonstrated no discernible drift after metering millions of litres of fuel — all were still perfectly calibrated. That means potential fuel savings of up to thousands of litres per year.

## Peerless performance and uncompromised control

The Xflo Meter's phenomenal accuracy and throughput are the result of revolutionary engineering and precision manufacturing. Wear and tear are minimized thanks to the Xflo Meter's design, featuring fewer moving parts and sealing surfaces. This limits the possibility of meter drift. The Xflo Meter also has multiple calibration points, providing you with better accuracy across the entire flow range.

## Extraordinarily adaptive

The Xflo Meter is both accurate and tough, making sure your investment lasts for years. Building on our tradition of dependable products, the Xflo Meter's efficient hydraulic design features tandem screw rotors made of hardened bearing steel in a compact housing. This rugged design is perfect for varied fuel environments. The Xflo Meter is built to handle millions of litres over its lifetime, in all flow conditions, fluid temperatures, densities and viscosities, and to be used with the same fuel types compatible with traditional piston meters.

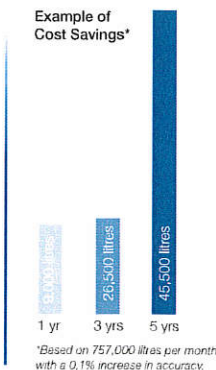

- Increase profits by eliminating fuel loss: save potentially thousands of litres every year.
- Protect your investment: virtually eliminate recalibration costs.
- Expect field-proven performance: over 3,000 meters successfully installed using similar/comparable technology.
- Improve your throughput: Wayne's fastest meter ever.

## Astonishing performance, outstanding security

At today's fuel prices, securing your investment is more important than ever. High-speed serial communication to the iGEM pump computer and a lack of exposed gear sets make the Xflo Meter highly resistant to tampering. Employing unique calibration tables and serial numbers that must be recognized by the iGEM enhances transaction security.

## Customer-centric innovation since 1891

Wayne engineers designed the Xflo Meter module to mount in the same form factor as existing iMeters installed in our recent dispenser models. This makes it easy to replace meters in existing dispensers with iGEM electronics (Global Star™, Ovation®, Global Ovation®). The Xflo Meter is available for use with E85 and Ultra High Capacity applications, with future plans for use in LPG applications.

[www.wayne.com](http://www.wayne.com)

Austin, Texas, USA | Malmö, Sweden | Rio de Janeiro, Brazil | Shanghai, China

© 2014, Wayne, the Wayne logo, Xflo, iGEM, Global Star, Ovation, Global Ovation and combinations thereof are trademarks or registered trademarks of Wayne Fueling Systems in the United States and other countries. Other names are for informational purposes and may be trademarks of their respective owners. All rights reserved.  
06295014/2 WFS140049-B

**Wayne**  
FUELING SYSTEMS