

Probe Description & Product Application	Stainless Steel Mag Plus In-Tank Probe for Monitoring Alternative Fluids with No Water Detection in both USTs and ASTs					
Specific Products Monitored / Product Compatibility	Part # & Description	Approved Products	Monitoring Functionality Options			
	Leak Detection / BIR - Accuchart Probes 1. 846397-4XX Stainless Steel (SS) In-Tank Probe with High Grade Polymer (HGP) Canister with No Water Detection & 0.1 GPH Testing Capability, UL 2. 846397-5XX SS In-Tank Probe with HGP Canister with No Water Detection & 0.2GPH Testing Capability, UL 3. 846391-4XX SS In-Tank Probe with Aluminum (AL) Canister with No Water Detection & 0.1 GPH Testing Capability, UL 4. 846391-5XX SS In-Tank Probe with AL Canister with No Water Detection & 0.2 GPH Testing Capability, UL No Leak Detection/Inventory Only Probes 1. 846397-6XX SS with HGP Canister with No Water Detection & No Leak Detection/ Inventory Only, UL 2. 846391-6XX SS with AL Canister with No Water Detection & No Leak Detection/ Inventory Only, UL	Alcohol (<=100% Alcohol)*	A. 0.1 GPH static in-tank testing for USTs only			
		Fuel Oil #6	B. 0.2GPH static in-tank testing for USTs only			
		Propylene Glycol	C. 0.2 GPH Continuous Statistical Leak Detection (CSLD) for USTs only			
		Methyl Alcohol*				
		Methanol (<=100% Alcohol)*	D. No Leak Detection / Inventory Only for USTs & ASTs			
		ETBE (<=100% Ether)	E. BIR – Accuchart for USTs only			
		Ethanol (<=100% Alcohol) includes E85*	* Limited to E85 for ATEX probes			
		MTBE (<=100% Ether)				
		Used Oil				
Ethylene Glycol						
Windshield Washer Fluid						
DEF (AdBlue)						
Console Compatibility	Maximum Probes / Console	Probe Interface Modules				
		Module Part #	Module Description	# of Modules per Console	# of Probe Inputs per Module	Availability
TLS-450PLUS (8600 Series) with TLS-XB installed (3 max per system)	64 (32 with BIR)	332812-001	Universal Sensor Module (USM) Interface for Probes, Sensors, and DPLLD	Up to 4	16	Sold Separately (either Factory Installed or as a Spare Module)
TLS4i (8601 Series)	4	No module required, probe input capability factory installed				
TLS4c (8601 Series)	2					
TLS-350/R/PLUS	16	329356-002	4-Input Probe Interface Module	4	4	Sold Separately (either Factory Installed or as a Spare Module)
TLS-300i	4	No module required, probe input capability factory installed				
TLS-300C	2					

	Part # & Description	Float Size	Cable Lengths	Min/Max Probe Length
Float Installation Kits	846400-0X4 Mag Plus Alternative Fluids Float Kit - No Water Float	4" (10.16cm)	5' (1.5m), 10' (3.05m), 20' (6.1m)	48" (1.2m) - 144" (3.66m)
	846400-3X4 Mag Plus Alternative Fluids Float Kit - No Water Float	3" (7.62cm)		
	846400-1X4 Mag Plus Alternative Fluids Float Kit - No Water Float	2" (5.08cm)		
Other Installation Accessories	312020-952 4" (10.16cm) NPT Riser Cap and Ring Kit for In-Tank Probes 330020-282 4" (10.16cm) Threaded NPT Riser Cap for In-Tank Probes			
Specifications	Product	Water		
Measurement Accuracy	+/- 0.0300" (0.762mm)	N/A		
Resolution - One Sample Reading	+/- 0.002857" (0.072571mm)	N/A		
Minimum Measurement - 2" (5.08cm) Float Kits	3.23" (8.2cm)	N/A		
Minimum Measurement - 3" (7.62cm) Float Kits	3.04" (7.72cm)	N/A		
Minimum Measurement - 4" (10.16cm) Float Kits	3.04" (7.72cm)	N/A		
Operating (Working) Temperature Range	-40 to +122°F (-40 to +50°C)			
Third Party Evaluation / Agency Listings & Links	UL, cUL, ATEX, IECEx http://www.nwglde.org/evals/veeder_root_j.html			
Product Installation Guide Link	https://www.veeder.com/us/technical-document-library			

Example Installation

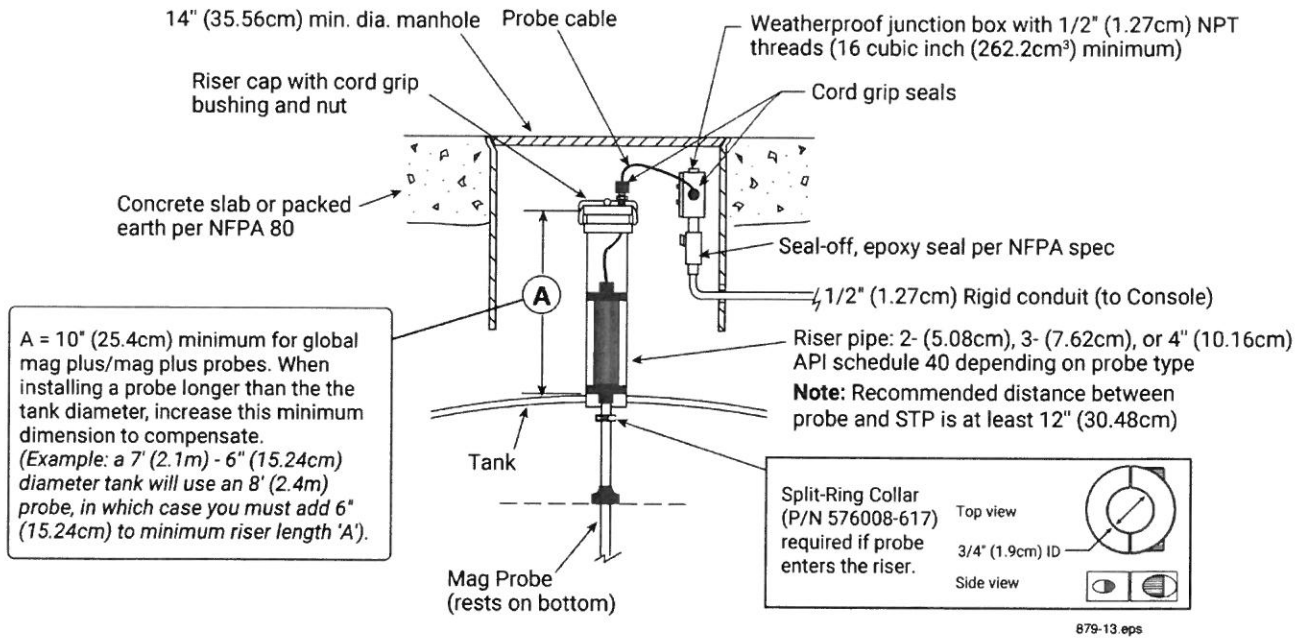

Notice

Veeder-Root makes no warranty of any kind with regard to this publication, including, but not limited to, the implied warranties of merchantability and fitness for a particular purpose.

Veeder-Root shall not be liable for errors contained herein or for incidental or consequential damages in connection with the furnishing, performance, or use of this publication.

Veeder-Root reserves the right to change system options or features, or the information contained in this publication.

This publication contains proprietary information which is protected by copyright. All rights reserved. No part of this publication may be photocopied, reproduced, or translated to another language without the prior written consent of Veeder-Root.

Example Illustrations

Illustrations used in this guide for example sensor installations may contain components that are customer supplied and not included with the sensor. Please check with your Veeder-Root Distributor for recommended installation accessories.

Third Party Evaluations

Third party evaluations of the Veeder-Root sensors contained in this application guide can be found under the Veeder-Root vendor name on the National Work Group on Leak Detection Evaluations (NWGLDE) website:

<http://www.nwglde.org>