

TOTAL CONTROL SYSTEMS

Toll: +1 (800) 348-4753
Tele: +1 (260) 484-0382
Fax: +1 (260) 484-9230
info@tcsometers.com
www.tcsometers.com

ENGINEERING MANUAL

682 SERIES PISTON FLOW METER

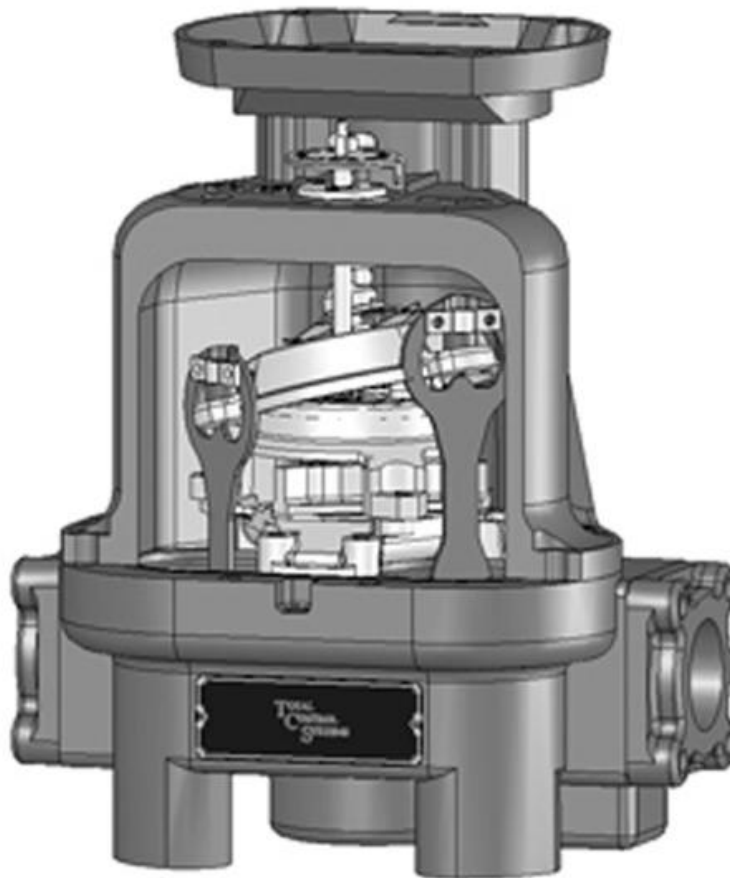

COMPATIBILITY CHART

<i>SOLUTION</i>	<i>VISCOSITY SSU</i>	<i>SPECIFIC GRAVITY</i>	<i>SP</i>	<i>SPA</i>	<i>SPD</i>	<i>AF</i>	<i>SS</i>
ALCOHOL, PROPYL		0.804	G	U	G	G	E
ALCOHOL, WHISKEY (<i>NOT SANITARY</i>)	150		U	U	U	U	E
ALCOHOL, WINE (<i>NOT SANITARY</i>)			U	U	U	U	E
ALKALI SOLUTION			U	U	U	G	E
ALKYD RESINS	50000		U	U	U	G	E
ALUMINUM CHLORIDE		2.44	U	U	U	U	U
ALUMINUM HYDROXIDE (10%)		2.42	U	U	U	U	E
ALUMINUM NITRATE			U	U	U	U	E
ALUMINUM SULFATE (50%, 125F)		2.71	U	U	U	U	F
AMINES			U	U	U	G	F
AMMONIA (32%)		0.99	U	U	U	G	E
AMMONIA, ANHYDROUS (NH3) (<i>USE TEFLON SEALS & COUNTER EXTENSION</i>)	30	0.70	U	U	U	U	U
AMMONIUM CARBONATE			U	U	U	G	E
AMMONIUM CHLORIDE	50	1.05	U	U	U	U	G
AMMONIUM HYDROXIDE	30	0.99	U	U	U	G	E
AMMONIUM NITRATE		1.73	U	U	U	F	E
AMMONIUM PHOSPHATE	50	1.62	U	U	U	U	F
AMMONIUM SULFATE		1.77	U	U	U	U	G
AMMONIUM SULFIDE			U	U	U	U	U
AMMONIUM SULFITE		1.41	U	U	U	U	U
AMYL ACETATE	30	0.88	U	U	U	G	G
ANILINE	40	1.02	U	U	U	G	E
ANIMAL FAT			U	U	U	G	E
ANITIFREEZE	88	1.10	E	E	E	E	E
ANTIMONY TRICHLORIDE			U	U	U	U	U
APPLE JUICE (<i>NOT SANITARY</i>)		1.06	U	U	U	U	E
AQUA AMMONIA			U	U	U	G	E
AQUA REGIA			U	U	U	U	U
AROMATIC SOLVENTS			U	U	E	E	E
ARSENIC ACID	50	2.0	U	U	U	U	G
ASPHALT (120F - 300F) (<i>USE HEAT EXTENSION & TRIM</i>)	2400 - 12000	1.1 - 1.5	U	U	U	G	E
ASPHALT EMULSION (75F) (<i>WATER BASED MAY CONTAIN CLAY</i>)	155 - 7000	1.0	U	U	U	G	E
AVIATION GASOLINE (AV GAS)	30	0.71	U	E	E	G	E
BACKDRAFT®, HERBICIDE			U	U	U	G	E
BARIUM HYDROXIDE		1.65	U	U	U	G	G
BARIUM NITRATE		3.24	U	U	U	F	E
BARIUM SULFATE			U	U	U	F	E
BARIUM SULFIDE		4.25	U	U	U	F	G
BARRICADE®, INSECTICIDE			U	U	U	E	E
BASAGRAN®, HERBICIDE			U	U	U	E	E
BEER	32	1.0	U	U	U	U	G
BEET SUGAR LIQUIDS			U	U	U	G	E
BENZALDEHYDE	40	1.05	U	U	U	G	E
BENZENE	31	0.90	U	U	U	G	G
BENZOIC ACID		1.27	U	U	U	U	G
BENZOL		1.04	U	U	U	G	G
BENZYL CHLORIDE		1.10	U	U	U	U	F
BICEP®, HERBICIDE			U	U	U	E	E
BIODIESEL FUEL (B100 @ 70F)	38	0.88	E	E	E	E	E

E = Excellent / Recommended
G = Good / Minor Effect
F = Fair / Moderate Effect
U = Not Recommended

This chart is intended as a chemical resistance guide rather than an unconditional rating since many system characteristics influence rate of corrosion and operation of meter; such as solution, viscosity, concentration, temperature, lubricity, presence of solids, pressure and flow rate. Ratings apply to liquids and solutions of commercial purity. Ratings do not imply Weights & Measures or UL conformance. Ratings for food type materials do not imply FDA conformance. Information compiled is based on published data and research performed by Total Control Systems. Total Control Systems cannot warranty, expressed or implied, that the laboratory results would be obtained under actual operating conditions.