

STP Serial Number Location

May 20, 2004 • TB012
Rev September 25, 2014

From June 2014

Franklin Fueling Systems has standardized serial number formats for FE Petro™ products. Below is shown the new format and how to read it. Also included are older formats to help you better identify existing products.

Location of Serial Number

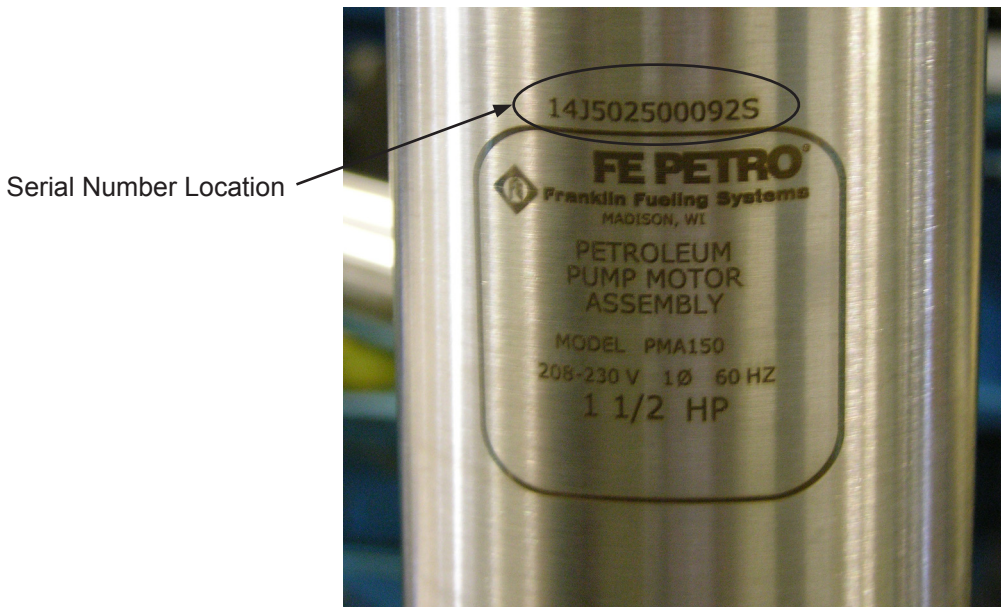

Location of Serial Number

Serial Number Format

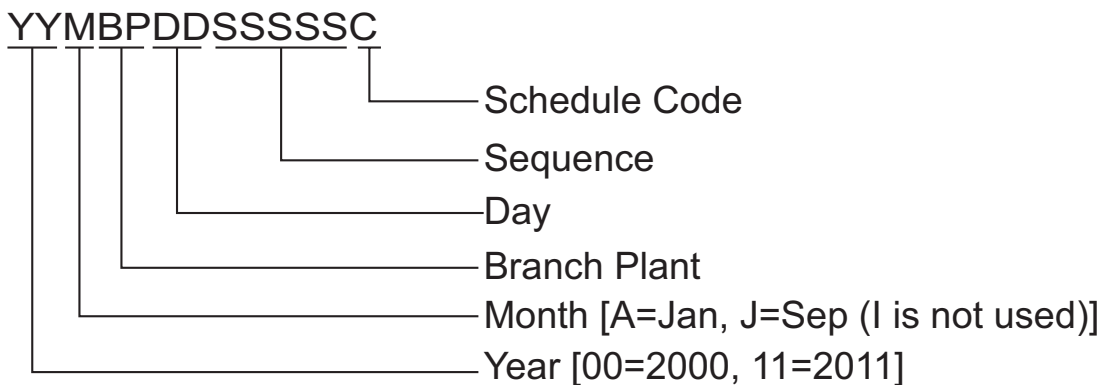

Examples

Serial Number	Explanation of Serial Number
14J502500092S	2014, September, Branch 50, 25 th day, 92 nd Unit, Schedule Code S
15K570301332S	2015, October, Branch 57, 3 rd day, 1332 nd Unit, Schedule Code S

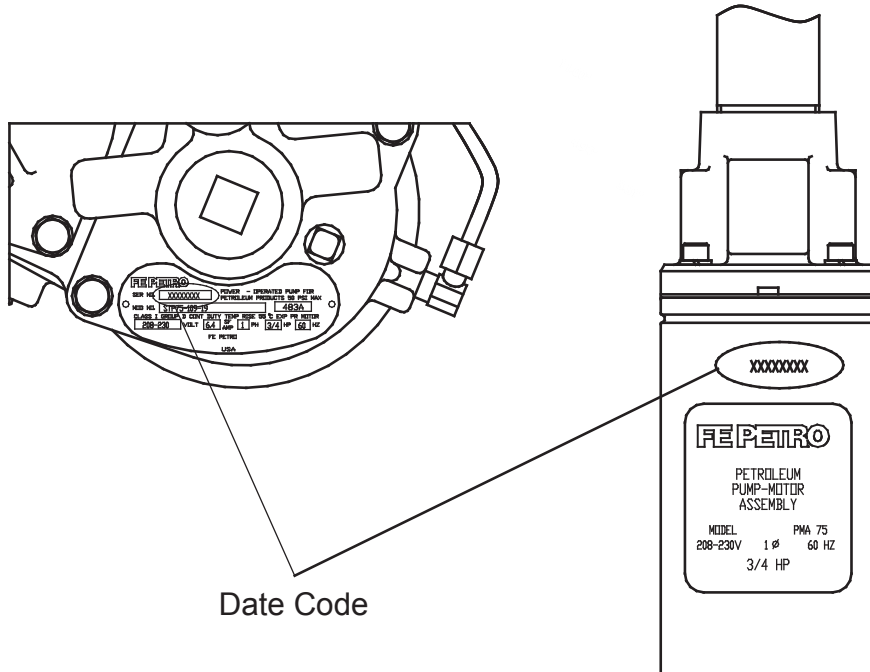

Date Code

Serial Number From July 1998 to May 2014

The serial number for all STPs, PMAs, STP-MLDs and other products is a date coded sequence. The first two digits indicate the year of manufacture, the second two digits indicate the month of manufacture, and the last four digits indicate the series unit number.

Examples

Identified on Product	Explanation of Serial Number
98071004	July, 1998 – 1004 th unit built
99010001	Jan., 1999 – 1 st unit built
00110293	Nov., 2000 – 293 rd unit built
01050598	May, 2001 – 598 th unit built

From 1988 to June 1998

First Letter = Month		Second Letter = Year		Three/Four Digit = Series Unit Number
A = Jan	G = July	A = 1989	G = 1995	(Refer to Product for Series Number)
B = Feb	H = Aug	B = 1990	H = 1996	
C = Mar	J = Sept	C = 1991	J = 1997	
D = Apr	K = Oct	D = 1992	K = 1998	
E = May	L = Nov	E = 1993		
F = June	M = Dec	F = 1994		