



☰ Show/Hide Menu

Defender Series®

## Spill Containers



Defender Series® single and double wall spill containers, available in both grade level and below grade models, provide a durable, easy-to-install, and simple-to-maintain and service spill containment solution for any environment and any application.

### HIGHLIGHTS

### SPECIFICATIONS

### ORDER INFO

### DOWNLOADS

## Approvals/Certifications

- UL Listed MH62435 (below grade, and grade level version with CI-GKT cover), ULC Listed (grade level CI-GKT versions only).
- CARB approved (grade level only).
- Cast-iron covers are engineered and tested to meet or exceed H20 and HS-20 load ratings.
- UL2447 listed for only those fuels formulated in accordance with 40CFR80, "Regulation of Fuels and Fuel Additives," and meeting the following ASTM fuel specifications and blend limit:
- ASTM D975 diesel with or without biodiesel blends up to 5% (B5)
  - ASTM D7467 diesel with biodiesel blends between 6% - 20% (B6 - B20)
  - ASTM D4814 gasoline with ethanol blends up to 10% (E10)
  - ASTM D5798 high-blend ethanol, with ethanol/gasoline blends between 51% - 83% (E51 - E83) - commercially known as "E-85"

E Fuel

- o Mid-range ethanol, with ethanol/gasoline blends of ASTM D4814 and ASTM D5798 blends between 11% - 50% (E11 - E50)
- In addition to UL2447 listed fuels, the following fuels are also compatible:
  - o Biodiesel up to 5% B5
  - o Biodiesel up to 20% B20
  - o Biodiesel at 97%-100% B99/B100
  - o All ASTM biofuel blends

*Bio*

## Components

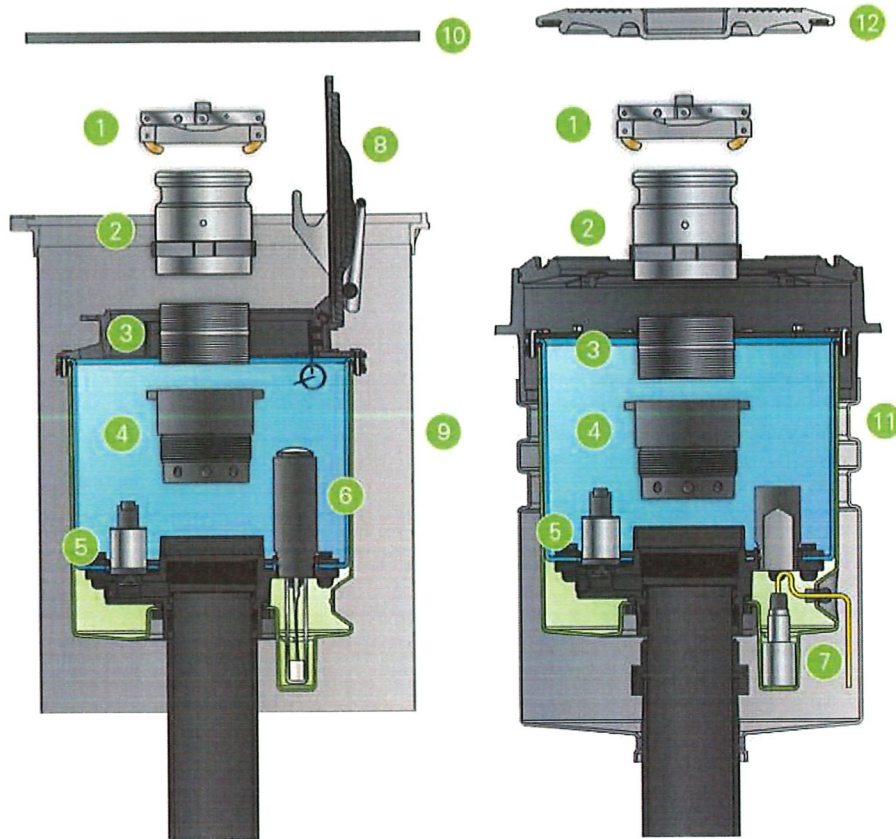

1. Adapter cap
2. Swivel adapter
3. Nipple
4. Drop tube adapter
5. Drain
6. Visual monitor
7. Electronic sensor monitor
8. Lock down lid
9. 18" manway
10. Fiberglass manyway lid
11. Gravel guard
12. Cast iron gasketed lid

## Grade Level Spill Container Dimensions

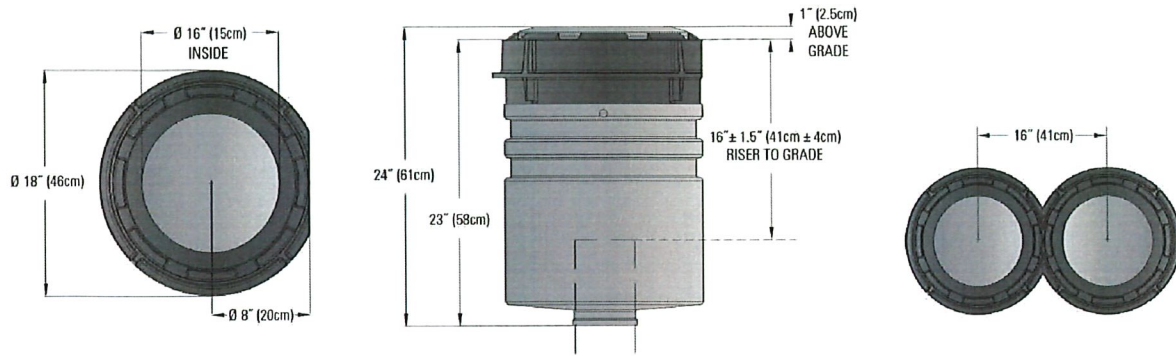

## Below Grade Spill Container Dimensions

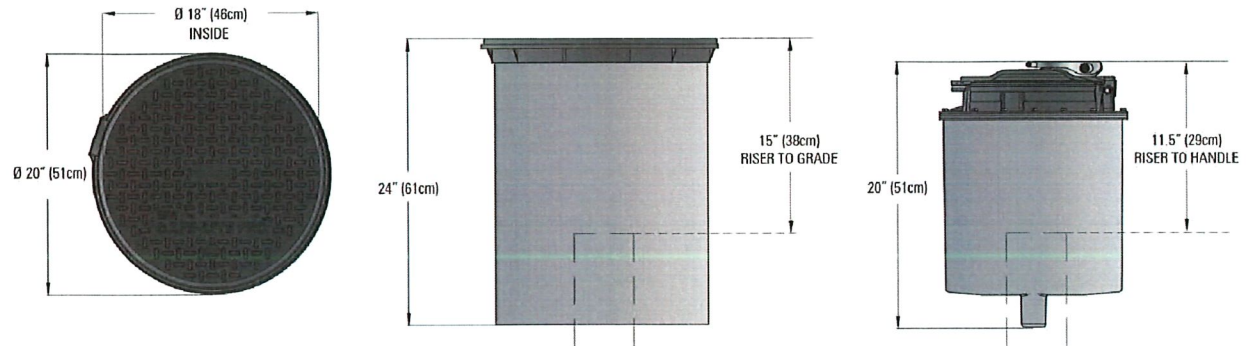

## Configurations

Below Grade  
Double Wall  
Visual Monitor

Below Grade  
Double Wall  
Electronic Monitor

Grade Level  
Single Wall

Grade Level  
Double Wall  
Visual Monitor

Grade Level  
Double Wall  
Electronic Monitor

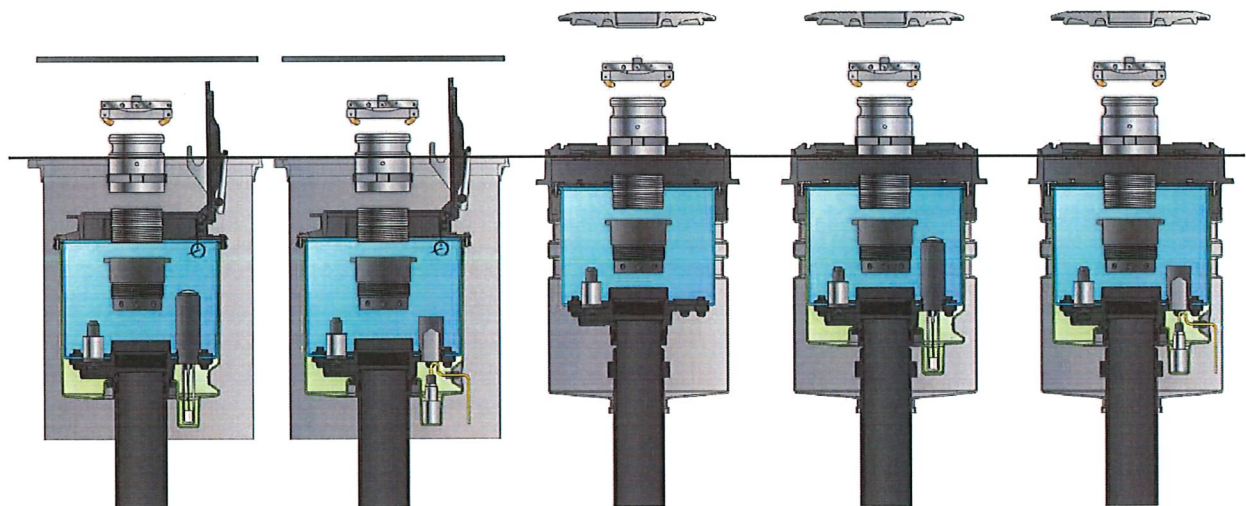

[Contact Us](#)  
[Corporate](#)  
[Job Opportunities](#)  
[Policies](#)  
[Legal Notices](#)