

DEFENDER SERIES® OVERFILL PREVENTION VALVE

The Defender Series® overfill prevention valve (OPV) is a self contained two-stage positive shut-off valve that prevents the overfill of an underground storage tank (UST) during a gravity-fed product delivery. The Defender Series® OPV employs a revolutionary magnetically-coupled actuator system to provide positive shutoff. This unique method of shutoff eliminates any penetrations in the valve, making it both vapor and leak tight. The Defender Series® OPV provides safe, rapid, and reliable fuel drops for the broadest range of fuel applications and environmental conditions. Simple to install, service and test remotely, the Defender Series® OPV is the industry's most versatile overfill prevention valve.

HIGHLIGHTS

- Magnetic coupler actuates the interior primary flapper assembly and secondary shut-off valve when the float rises outside of the valve, eliminating valve body penetrations and any potential product or vapor leak points.
- After cutting to length in the field, the upper drop tube is roll-crimped onto a top adapter outfitted with two O-rings and then threaded onto the top of the valve body, eliminating the need for drilling, rivets, epoxy, and flaring tools.
- Bottom drop tube is cut in the field and threaded onto the bottom of the valve ensuring straight installation.
- The roll-crimp/thread method of installing drop tubes ensures proper alignment of the drop tubes with the rest of the OPV assembly, making installation and removal of the entire assembly smooth.
- Damaged drop tubes can be easily replaced instead of having to purchase an entire new assembly.
- Fully compatible with gas, gas/alcohol blends, diesel and biodiesel.
- Compatible with industry standard 4" drop tubes allowing retrofit into existing installations.
- The entire OPV assembly remains within the 4" inner diameter of the riser preventing interference with other tank components and also allowing removal even while the tank is full.
- Actuates in both low and high flow applications and functions within a broad range of flow rates from 25 gpm to 370 gpm (95 lpm to 1,400 lpm).
- The remote testing tool allows for remote testing of the primary functionality without having to remove the OPV from the riser.

SPECIFICATIONS

Approvals/Certifications

- ULc listed
- ATEX approved
- CARB certified

Dimensions

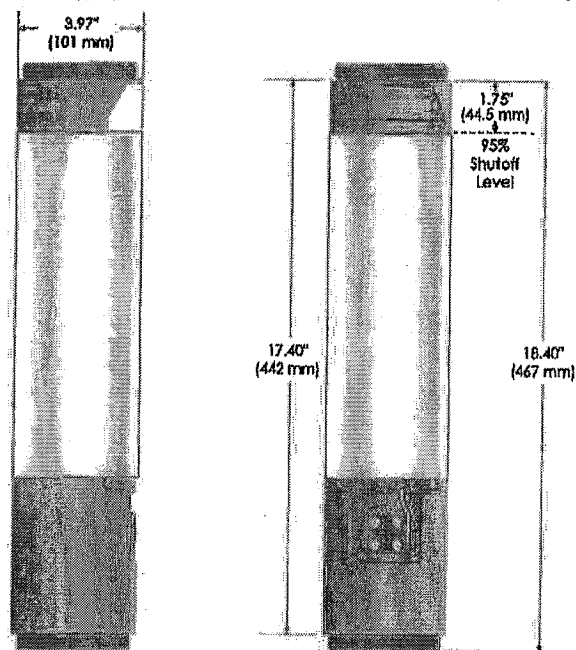

SPECIFICATIONS CONTINUED

Components

- Pre-flanged aluminum top drop tube
- Roll-crimped top fitting/drop tube
- Protective float sleeve
- Float (shielded by float sleeve)
- Valve assembly
- Magnetically-coupled actuator
- Threaded bottom drop tube

Operation

The OPV is designed with a primary shutoff that will activate between 85% and 92% of tank volume, depending on tank size. After the primary shutoff is actuated the flow through the valve is limited to less than 8 gpm (30 lpm). A secondary positive shutoff will occur at 95% tank volume if filling continues.

As the liquid level in the tank rises, it raises a float. As the float rises it actuates the external/internal magnetic couplers which release the flapper to be closed by the flow of product. As the float continues to rise, the internal mechanism pushes the flapper further into the product flow to allow actuation at high or low flow rates. This sudden reduction in flow caused by the primary flapper closing creates "line shock" to the fill hose which signals the delivery driver that the tank is nearing capacity. As the float continues to rise to the 95% fill level, the secondary closes, completely stopping the flow of fuel.

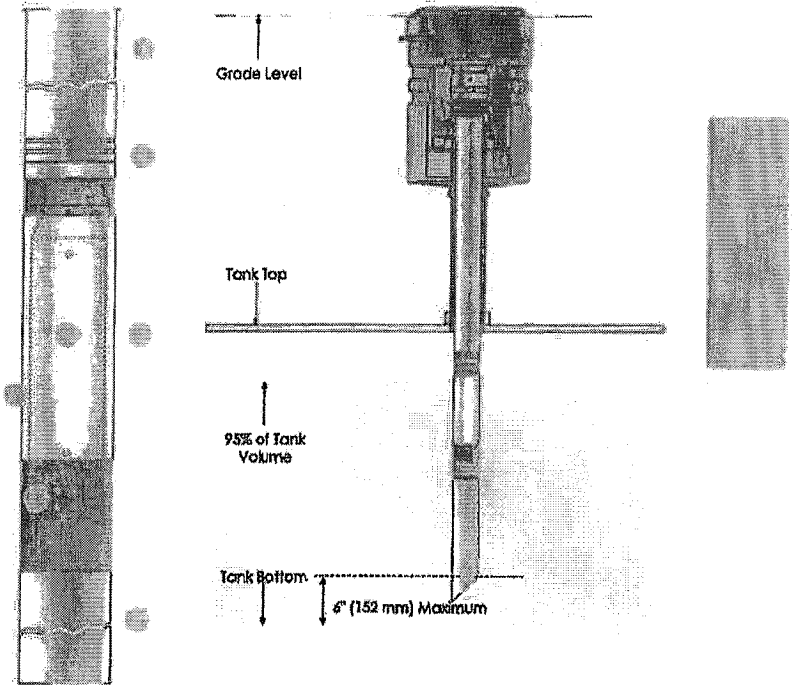

ORDERING INFORMATION

708591901	Defender Series® overfill prevention valve with 5' (1524mm) top drop tube, 8' (2438mm) bottom drop tube
708591902	Defender Series® overfill prevention valve with 5' (1524mm) top drop tube, 10' (3048mm) bottom drop tube
708591921	Defender Series® overfill prevention valve with 5' (1524mm) top drop tube, 8' (2438mm) bottom drop tube, AGB compatible*
708591922	Defender Series® overfill prevention valve with 5' (1524mm) top drop tube, 10' (3048mm) bottom drop tube, AGB compatible*
708592901	Defender Series® overfill prevention valve with 10' (3048mm) top drop tube, 8' (2438mm) bottom drop tube
708592902	Defender Series® overfill prevention valve with 10' (3048mm) top drop tube, 10' (3048mm) bottom drop tube
708592921	Defender Series® overfill prevention valve with 10' (3048mm) top drop tube, 8' (2438mm) bottom drop tube, AGB compatible*
708592922	Defender Series® overfill prevention valve with 10' (3048mm) top drop tube, 10' (3048mm) bottom drop tube, AGB compatible*
708593901	Defender Series® overfill prevention valve, coaxial with 6.5' (1981mm) top drop tube, 8' (2438mm) bottom drop tube
708593902	Defender Series® overfill prevention valve, coaxial with 6.5' (1981mm) top drop tube, 10' (3048mm) bottom drop tube
708593923	Defender Series® overfill prevention valve, poppeted coaxial with 6.5' (1981mm) top drop tube, 8' (2438mm) bottom drop tube*
708593924	Defender Series® overfill prevention valve, poppeted coaxial with 6.5' (1981mm) top drop tube, 10' (3048mm) bottom drop tube*
708594901	Defender Series® overfill prevention valve only with top adapter, AGB compatible*
708594902	Defender Series® overfill prevention valve only with coaxial top adapter, AGB compatible*
708556901	Defender Series® remote fill splice kit
708535901	Roll crimping tool
708530930	Replacement roll crimping tool roller bit for retrofit with existing tool
708534901	Remote testing tool, 11' (3353mm) long sectional/collapsible

*Alcohol, gas, biofuel compatible (E-85, gasoline and biodiesel) models come with hard coated anodized drop tubes for full compatibility.



Franklin Fueling Systems

franklinfueling.com
 3780 Marsh Rd. • Madison, WI 53718, USA
 Tel: +1 608 838 8786 • Fax: +1 608 838 6433
 Tel: USA & Canada +1 800 225 9787 • Tel: UK +44 (0) 1473 243300
 Tel: Mex 001 800 738 7610 • Tel: FR +33 (0) 1 69 21 41 41 • Tel: CH +86 10 8565 4565



© 2019 Franklin Fueling Systems. All Rights Reserved.

FFS-0392 03-19