



DIGITAL INVENTORY & LEAK DETECTION PROBES

Digital inventory and leak detection probes provide accurate tank level monitoring and reporting with optional leak detection capabilities. These probes employ digital communications and magnetostrictive position measurement technology for highly accurate tank readings.

HIGHLIGHTS

- Models available for inventory control or inventory control with leak detection.
- Capable of precise leak detection, density measurement, and inventory monitoring.
- Suitable for use with gasoline, diesel, DEF/AdBlue®, and other manufacturer approved products.
- Bottom mounted installation for fast and simple install.
- Screw-in electrical connector provides quick installation or removal, eliminating the need to re-splice wires.
- Highly accurate digital communication between the probe and the tank gauge.
- Probes are available in many sizes that are suitable for all common tanks.
- Easily installed into 2", 3" or 4" riser pipes.

SPECIFICATIONS

Operating Temperature	-40° to 140° F (-40° to 60° C)
Storage Temperature	-40° to 158° F (-40° to 70° C)
Non-linearity	±0.025% of full scale
Repeatability	±0.001"
Temperature Sensors	5 thermistors located in the shaft
Temperature Resolution	±0.02° F (±0.01° C)
Probe Cable	10' long three conductor cables with shields and polyurethane jacket
Float Compatibility	Up to 3 floats for product, water, phase separation detection, or density measurement
ATG Compatibility	EVO™ Series, TS-5, TS-550, TS-5000, Colibri®, TS-1001/2011/750/504/508
Fuel Compatibility	Diesel with or without biodiesel blends up to 5% (B5), diesel with biodiesel blends between 6% - 20% (B6 - B20), diesel with biodiesel blends between 97% - 100% (B99 - B100), gasoline with ethanol blends up to 10% (E10), mid-range ethanol/gasoline blends of (E15-20), high-range ethanol/gasoline blends (E51-83) commercially sold as E85
Approvals/Certifications	UL & cUL listed, ATEX, IECEx



Inventory & Leak Detection Probe (Shown with optional precision density diesel float kit)

Inventory Probe (Shown with optional 4" gas float kit)

SPECIFICATIONS CONTINUED

Components

- 1 Probe head
- 2 Guides
- 3 Bottom mount fitting
- 4 Probe shaft
- 5 2" or 4" gas or diesel product float (sold as kit with water float)
- 6 2" or 4" gas or diesel water floats (sold as kit with product float)
- 7 Precision or standard density float kit
- 8 Phase separation float kit
- 9 Low level water float kit for diesel
- 10 LPG float
- 11 Chemical float

Note: All float kits sold separately.

Operation

An electromagnetic field is created inside the probe head and forms around a long waveguide within the probe shaft when position measurements are taken. The electromagnetic field interacts with the magnetic field of the float(s) and produces a shock wave in the waveguide that travels at a known speed. When the shock wave is detected at the probe head, the probe creates a signal that corresponds precisely to the product level. Product expansion calculations are enabled by temperature sensors that are located at various points in the probe shaft.

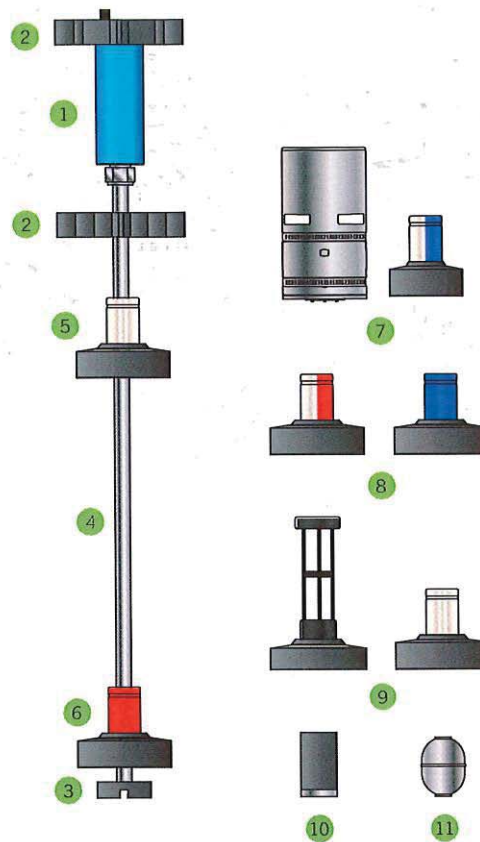

Minimum Detectable Water Level

Float Type	Minimum Detectable Water Level
TSP-IGF4 / TSP-IGFD3 Gasoline Floats	0.75" (1.91 cm)
TSP-IDF4 / TSP-IGF4D3 Diesel Floats	0.75" (1.91 cm)
TSP-IGF4P Phase Separation Float	0.44" (1.12 cm)
FMP-IDF4E Low Level Water for Diesel Float	0.25" (0.64 cm)

ORDERING INFORMATION

Leak Detection Probes

Model	Description
FMP-LL3-29	2' digital leak detection probe
FMP-LL3-41	3' digital leak detection probe
FMP-LL3-53	4' digital leak detection probe
FMP-LL3-65	5' digital leak detection probe
FMP-LL3-69	5'4" digital leak detection probe
FMP-LL3-77	6' digital leak detection probe
FMP-LL3-81	6'4" digital leak detection probe
FMP-LL3-89	7' digital leak detection probe
FMP-LL3-101	8' digital leak detection probe
FMP-LL3-113	9' digital leak detection probe
FMP-LL3-125	10' digital leak detection probe
FMP-LL3-131	10'6" digital leak detection probe
FMP-LL3-137	11' digital leak detection probe
FMP-LL3-149	12' digital leak detection probe

Applications

- The leak detection probes are typically used for underground storage tanks and petroleum applications when static or SCALD leak detection is required.
- The inventory control probes are typically used for aboveground storage tanks, chemical or oil waste, or underground storage tanks that do not require in-tank leak detection.

Inventory Control Probes

Model	Description
FMP-LL3-29-I	2' digital inventory control probe
FMP-LL3-41-I	3' digital inventory control probe
FMP-LL3-53-I	4' digital inventory control probe
FMP-LL3-65-I	5' digital inventory control probe
FMP-LL3-69-I	5'4" digital inventory control probe
FMP-LL3-77-I	6' digital inventory control probe
FMP-LL3-81-I	6'4" digital inventory control probe
FMP-LL3-89-I	7' digital inventory control probe
FMP-LL3-101-I	8' digital inventory control probe
FMP-LL3-113-I	9' digital inventory control probe
FMP-LL3-125-I	10' digital inventory control probe
FMP-LL3-131-I	10'6" digital inventory control probe
FMP-LL3-137-I	11' digital inventory control probe
FMP-LL3-149-I	12' digital inventory control probe

Note: Additional probe lengths are available. Please contact your Territory Sales Manager for more information.

3760 Marsh Rd. • Madison, WI 53718
www.franklinfueling.com • +1 844.344.5025

© 2023 Franklin Electric Co., Inc. All Rights Reserved.

FFS-0434 05-23